

WILSON
AUDIO



TUNE TOT™

INSTALLATION AND CARE GUIDE



Wilson Audio® is a registered trademark of Wilson Audio Specialties, Inc.

Sophia®, Sasha W/P®, WAMM®, MAXX®, XLF®, and Alexandria® are registered trademarks of Wilson Audio Specialties, Inc.

Sabrina™, Alexx™, Yvette™, Alida™, Alexia™, WilsonGloss™, Wilson Audio Duet™, WATCH Center™, WATCH Surround™, WATCH Dog™, TuneTot™ and Thor’s Hammer™ are trademarks of Wilson Audio Specialties, Inc.

This manual was produced by the Wilson Audio Engineering and the Sales and Marketing Department. The information contained herein is subject to change without notice. Current Revision 1.0. If you are in need of a more recent manual, please contact your dealer or download one at www.wilsonaudio.com.

The information in this manual is the sole property of Wilson Audio Specialties, Inc. Any reproduction, in whole or in part, without the express written permission of Wilson Audio Specialties, Inc., is prohibited. No material contained herein may be transmitted in any form or by any means, electronic or mechanical, for any purpose, without the express written permission of Wilson Audio Specialties, Inc.

Copyright © 2016 Wilson Audio Specialties

CONTENTS

SECTION 1—TUNETOT ASSEMBLY 7

SECTION 1.1—BOX CONTENT CHECKLIST 8

SECTION 1.2—TUNETOT TOOLKIT 9

SECTION 1.3—CHOOSING THE BEST LOCATION 9

SECTION 2—SETUP OF TUNETOT 11

SECTION 2.1—ASSEMBLING TUNETOT..... 12

INSTALLING THE SPIKES 12

SECTION 2.2—REFINING THE POSITION OF TUNETOT..... 13

FINDING THE CORRECT POSITION..... 13

SECTION 2.3—CORRECTING FOR THE TIME DOMAIN 14

TIME DOMAIN SETUP 14

SECTION 2.4—LEVELING TUNETOT 15

SECTION 2.5—REMOVING THE PROTECTIVE FILM..... 16

SECTION 2.6—CONNECTING TUNETOT TO AN AMPLIFIER 17

SECTION 2.7—PORT PLUG..... 18

4 TUNETOT INSTALLATION AND CARE GUIDE

SECTION 2.8—RESISTORS	19
SECTION 3—SPECIFICATIONS	23
SECTION 3.1—SPECIFICATIONS	24
SECTION 3.2—GRAPHICAL DIMENSIONS	25
SECTION 3.3—TUNETOT PHASE CURVE	26
SECTION 3.4—TUNETOT IMPEDANCE CURVE	27
SECTION 4—TUNETOT ECOSYSTEM	29
SECTION 4.1—TUNETOT ISOBASE™	30
INSTALLING ISOBASE	30
SECTION 4.2—TUNETOT GRILLE	31
SECTION 4.3—TUNETOT DRIVER RING	31
SECTION 5—WARRANTY	33
SECTION 5.1—WARRANTY DETAILS	34
LIMITED WARRANTY	34
CONDITIONS	34
REMEDY	35

AUTHENTIC EXCELLENCE™

TABLE OF CONTENTS 5

WARRANTY LIMITED TO ORIGINAL PURCHASER	35
DEMONSTRATION EQUIPMENT	35
MISCELLANEOUS	36





SECTION 1—TUNETOT ASSEMBLY

Note: In the area you intend to install your TuneTots, clear out two spaces, one for your left and one for your right channel. Place the ODD numbered TuneTot in the LEFT channel section and the EVEN in the RIGHT channel section.

Section 1.1—Box Content Checklist

Now that you have unpacked your TuneTot, you can inventory all the additional items in the boxes.

- Owners Manual
- Warranty Registration Form
- (1x) Polishing Cloth
- (4x) 3/8"-16 Custom Adjustable Spike with Nut
- (8x) Small Aluminum Spike Pad
- (4x) "AA" Spike (Stainless)
- 9/16" x 7/16" Combo Wrench. (Spike nuts & "AA" spike)
- 1/8" Allen (resistor panel screw, driver screws)
- New Tool Kit Box
- New Tool Kit Foam Inserts
- New Speaker Box
- New Speaker Box Foam Inserts
- Foam vent/port plug

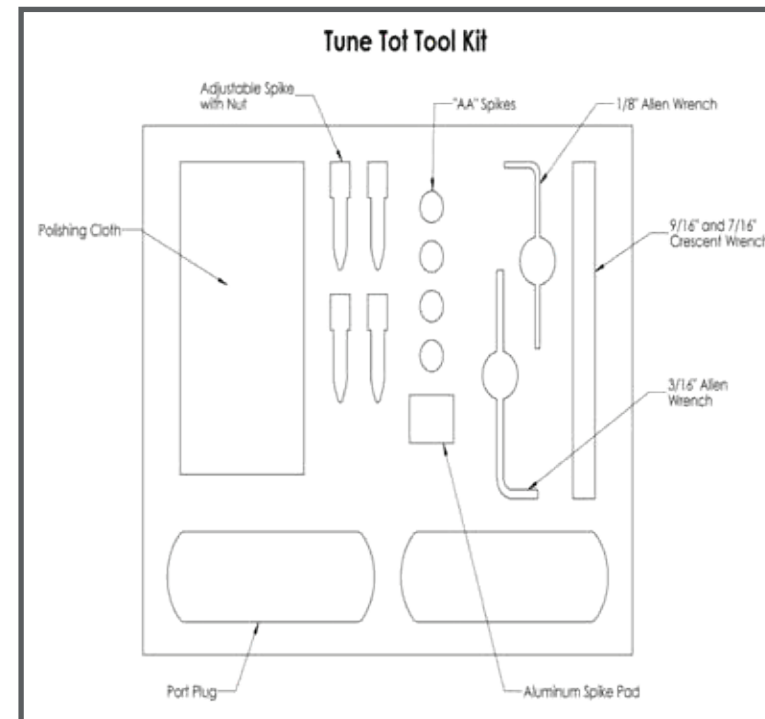

- Packing Sticker(s)
- Promo Inserts
- Full Wilson Audio Product Line Brochure

Section 1.2—TuneTot Toolkit

Please take the time before you attempt to setup up your TuneTot to review the contents of your TuneTot tool and spike kit. Set these items in an accessible area as you will need them during the setup process. See the graphic on the next page.

You will be using tools and parts in this kit throughout the installation process. Keep TuneTot toolkit at hand.

Section 1.3—Choosing the Best Location

TuneTot is designed to be used primarily on bookshelves, credenzas, counters and desk tops. As such, much of the process used by Wilson Setup experts is less applicable. However, TuneTot is a very high resolution transducer, and benefits from careful attention to the details and its position. If you want to learn more about the Wilson Audio setup procedure, which can form a good basis of understanding for how to place your TuneTots, you can do so by viewing a short video by scanning the QR code to the left.





SECTION 2—SETUP OF TUNETOT

Section 2.1—Assembling TuneTot

Installing the Spikes

TuneTot uses two types of spikes, the AA-sized fixed spike, and the Adjustable spike, which incorporates a locking nut. These two sets of spikes together form the time-domain and leveling system for TuneTot.

1. There are four threaded receptacles located on the bottom of TuneTot. It is shipped with threaded plugs that maintain a gas-tight seal if the spikes are not installed. Remove the four bolts.
2. Locate the two sets of spikes. These can be found in the tool box. Remove all eight spikes. Stage two AAs and two Adjustable spikes for each TuneTot.
3. With the help of an assistant, measure your ear (using the ear canal as the reference point) height from the floor. Then measure the distance from the floor to the top of TuneTot's woofer driver. The purpose of these measurements is to determine the overall relationship of the listener to TuneTot.
4. If the distance from the listener's ear to the floor is greater than the distance of TuneTot to the floor (the listener is generally higher than TuneTot), then install the adjustable spikes into the front two TuneTot spike receptacles, and the two AA



spikes into rear two receptacles.

5. If the distance from the listener's ear to the floor is less than the distance from the floor to TuneTot (the listener is positioned below TuneTot), then install the adjustable spikes into the rear of TuneTot's two receptacles, and the two AA spikes into the front two.
6. At this point, leave the nuts on the Adjustable spike loose enough to allow the spike to be adjusted freely by hand.

Section 2.2—Refining the Position Of TuneTot

Finding the Correct Position

TuneTot benefits from fine tuning both side-to-side as well as front-to-back tuning, within the constraints and limits of the shelf.

TuneTots should be "toed-in" directly toward the listener, such that, from the seated position, the listener sees only a small portion of the outside of each cabinet.

Note: Please note that TuneTot's spikes are somewhat sharp. Wilson supplies spike pads that optionally sit beneath the spike if there is a need to protect the surface below.

Section 2.3—Correcting for the Time Domain

Like all ultra-high performance loudspeakers, TuneTot will sound far more lifelike if the time domain is properly corrected. In a compact two-way design such as TuneTot, this can be effectively achieved by angling the baffle in correct relationship to the listener. When the time domain is properly adjusted in a Tune-Tot installation, every aspect of sound reproduction is improved—including tonal accuracy and beauty, transient speed, soundstage and imaging, and a sense of dynamic contrast.

Time Domain Setup

Wilson engineers have devised a simple and effective method for achieving the correct time domain for each installation with TuneTot. The correct baffle angle in relationship to the viewer is achieved visually. In the case of TuneTot, baffle angle and correct time domain are interchangeable. Wilson’s engineers determined that if there is a correct amount of “reveal” on the top plane of TuneTot’s cabinet, as seen from the listening position, it is a reliable indicator for correct time domain in relationship of TuneTot to the listener.

This is accomplished via the following process:

1. Make sure that your TuneTots are properly positioned with correct “toe” as outlined in the previous section.
2. The listener should be in the listening position, his/her posture



relaxed as he/she would be when listening to TuneTot.

3. View the reveal of the top plane of TuneTot’s cabinet.
4. If there is too little reveal and the Adjustable spikes are installed in the front receptacles, then decrease the length of the spikes.
5. If there is too little reveal, and the Adjustable spikes are installed in the rear receptacles, then decrease the length of the spikes.
6. If there is too much reveal and the Adjustable spikes are installed in the front receptacles, then increase the length of the spikes.
7. If there is too much reveal and the Adjustable spike are installed in the rear receptacles, then decrease the length of the spikes.
8. Repeat this process until there is an appropriate amount of reveal for each speaker. (See illustrations to the left.)

Section 2.4—Leveling TuneTot

1. Check the solidity of TuneTot on its spikes. If one of the Adjustable spikes is out of level, TuneTot will rock.

2. Lay a 10" digital level, such as the Husky, horizontally on the top plane of TuneTot. Check the level.
3. You may rotate the spike tips in place by hand. Lengthen the appropriate spike or spikes on the lower side until TuneTot is level. You may rotate the spike tips in place by hand.
4. Adjust the Adjustable spikes until TuneTot is level side-to-side, and providing a solid, level mount with no rocking.
5. Recheck to make sure that TuneTot is still positioned for correct time domain.
6. Using the supplied 9/16" wrench, and taking care to avoid moving TuneTot out of position, tighten the nuts installed on the Adjustable spike by sliding the wrench in the space beneath TuneTot. Tighten the nuts such that they are locked and secure against the bottom of the cabinet. **Do not overtighten.**

Section 2.5—Removing the Protective Film

To protect the finish of TuneTot during final manufacture, shipment, and setup in your listening room, we have applied a removable layer of protective film over the finish. We recommend that this film be left in place until the speakers are in their final location in your listening room. Once you have determined their

final position, remove the film by following this procedure:

1. Ensure the speaker surface is room temperature before removing the protective film.

Note: Removing the protective film when the speaker surface is cold can damage the paint surface.

2. Slowly remove the film from the top down, large sections at a time, gently pulling the film downward and outward.

Note: Tearing the film aggressively can damage the paint.

3. Take care in removing the protective film near edges and corners to prevent paint damage in these areas.
4. The protective film should not be left on the painted surface for extended periods of time nor exposed to heat sources and direct sunlight.

Section 2.6—Connecting TuneTot to an Amplifier

High quality "five-way" binding post connections are provided to facilitate connecting TuneTot to your amplifier. Several different types of speaker-cable hardware are compatible with the post, including spades and banana-style connectors. Attach the main output from the amplifier to the binding posts located on the bottom rear of the TuneTot. Use your fingers to tighten the binding posts.

Do not overtighten.

Section 2.7—Port Plug

Unlike Wilson’s floorstanding loudspeakers, which are typically installed in a relatively predictable environment with some distance from the room’s boundaries, TuneTot was designed to be installed into more acoustically hostile areas, such as desktops, bookshelves, and counter tops.

TuneTot features an acoustically tune rear vented. Wilson engineers determined that this configuration offers the best combination of low port noise and optimized port contribution in the low frequency portion of the spectrum of TuneTot. Occasionally, the combination of TuneTot’s proximity to a shelf or counter top and a rear wall can reinforce this port energy and cause undesirable reinforcement and nonlinearities in this portion of the bandwidth.

Wilson’s engineers have provided a solution for these types of installations. TuneTot is shipped with two port plugs. These are located in TuneTot’s toolbox.

If the bass sounds integrated with the rest of the tonal spectrum, features dynamic authority and transient speed in the midbass, there is little need to experiment with the port plug. However, if the bass sounds bloated, “woolly” or slow, these are symptoms of an excess of boundary reinforcement.

Use the following process experiment with the port plug, as well as the method to safely install the plug.



- Pick a musical track that has bass extension and dynamics. If possible, choose a thirty second (or so) section of the track, and repeat that section using the A/B repeat feature of your CD player. Listen to several repetitions without the plug installed.

Note: Wilson has a bass setup CD with the appropriate musical tracks optimized for this purpose. This CD is available on Wilson’s on-line store.

- The plug is formed to fit snugly in the port. With the flat-surfaced end out, gently push the port plug into the vent, making sure the flat flange of the plug rests tightly against the external edges of the vent.
- Restart the musical selection. Listen for improved bass integration, speed, and articulation. If the bass is more musically satisfying, this is the preferred configuration.

Note: This process benefits from repeated listening. Repeat the steps to ensure your choice of vented or un-vented yields the most musical results.

Section 2.8—Resistors

By removing the aluminum back cover on the rear of TuneTot, you gain access to the resistors. The back cover is secured by Allen bolts. Use the supplied Allen wrench to remove the four bolts.

The tweeter resistors, which consists of a 11.75Ω (2 X 23.5Ω in paral-

20 TUNETOT INSTALLATION AND CARE GUIDE

lel) resistor assembly for tweeter protection and level. The resistors provide precise level matching between the woofer and tweeter drivers. The resistors also act as ultra-high-quality fuses which open before a driver can be damaged by excess power.

In rare instances for some installations, it is desirable to alter the level of the tweeter to overcome tonal balance problems. There is a resistor fine-tuning kit available from Wilson Audio's on-line store should they be needed.

Note: Only Wilson Audio replacement resistors should be used in your TuneTots. Changing the value or brand of the resistors will have a deleterious affect on the sonic performance of your loudspeakers and will void your Wilson Audio Warranty.





SECTION 3—SPECIFICATIONS

Section 3.1—Specifications

Enclosure Type Woofer: Rear Vented

Enclosure Type Tweeter: Sealed

Woofers: 5.75 inches (14.61 cm) Doped Paper Pulp

Tweeter: 1 inch (2.54 cm) Doped Silk Fabric

Sensitivity: 86 dB @ 1W @ 1m @ 1k

Nominal Impedance: 8 ohms / minimum 6.61 ohms @ 172 Hz

Minimum Amplifier Power: 25 Watts per channel

Frequency Response: 65 Hz—23 kHz +/- 3 dB Room Average Response [RAR]

Overall Dimensions: Height—14.83 inches (37.67 cm) w/o spikes

Width—8.61 inches (21.87 cm)

Depth—10.19 inches (25.88 cm)

System Weight Per Channel: 29 lbs (13.15 kg)

Total System Shipping Weight (approx.): 70 lbs (31.75 kg)

Section 3.2—Graphical Dimensions

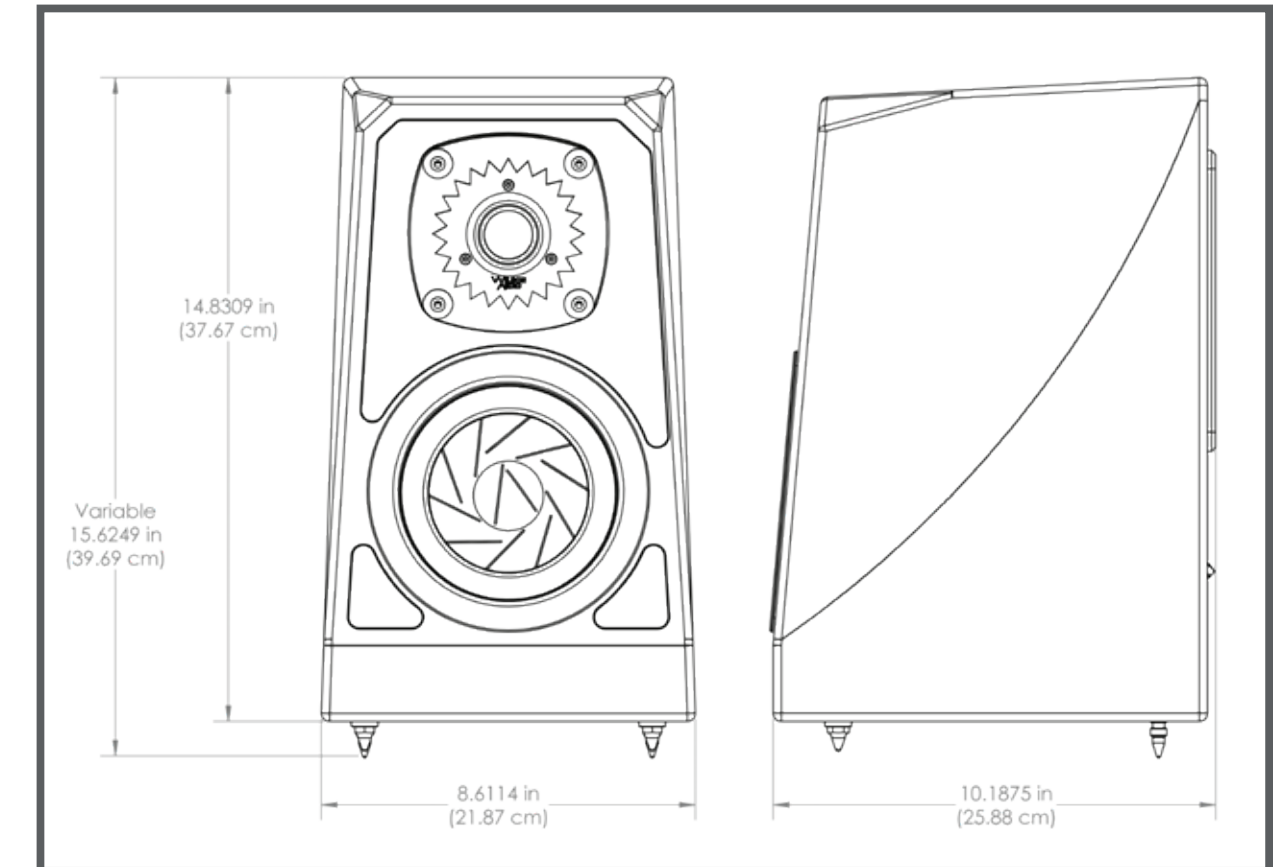

Section 3.3—TuneTot Phase Curve

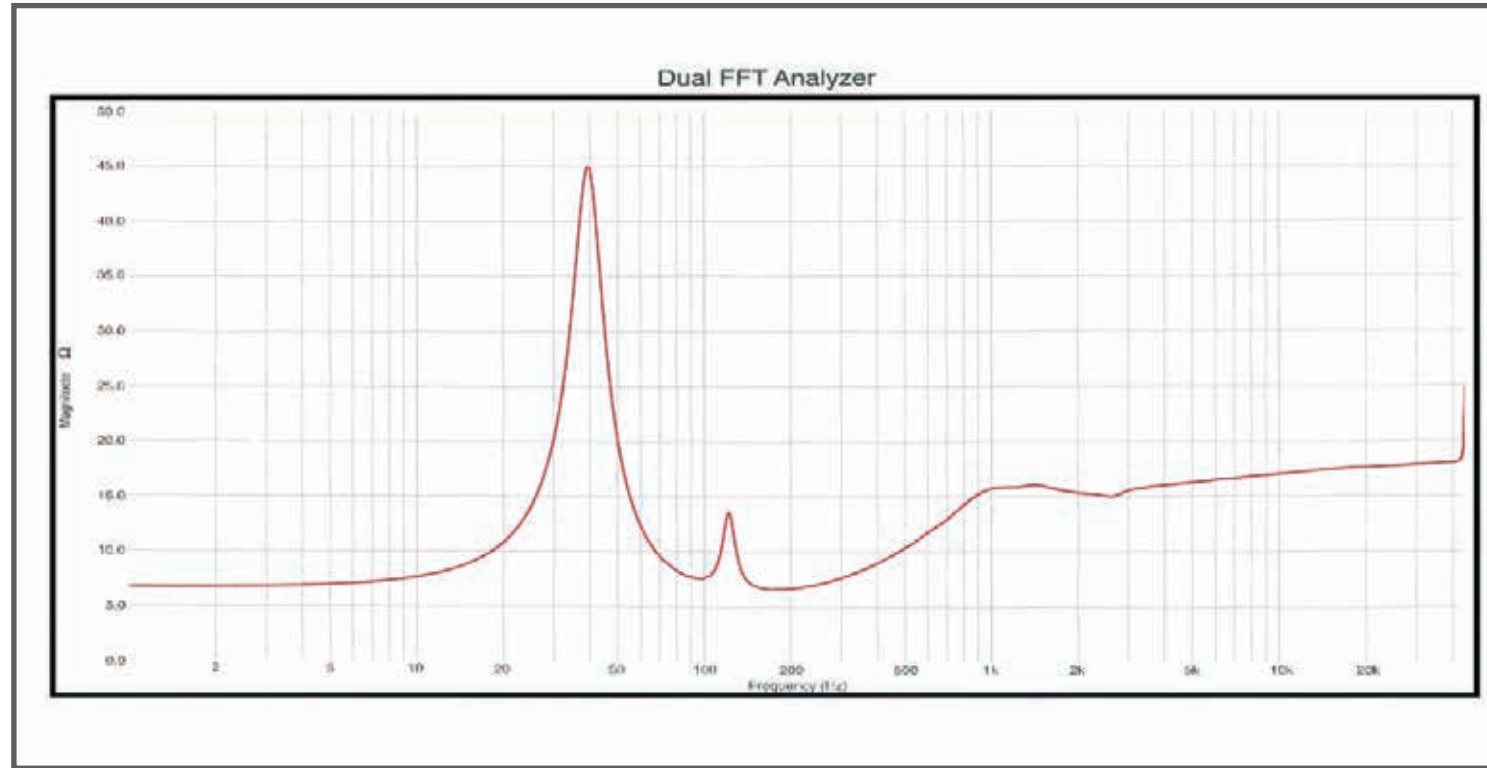

Section 3.4—TuneTot Impedance Curve

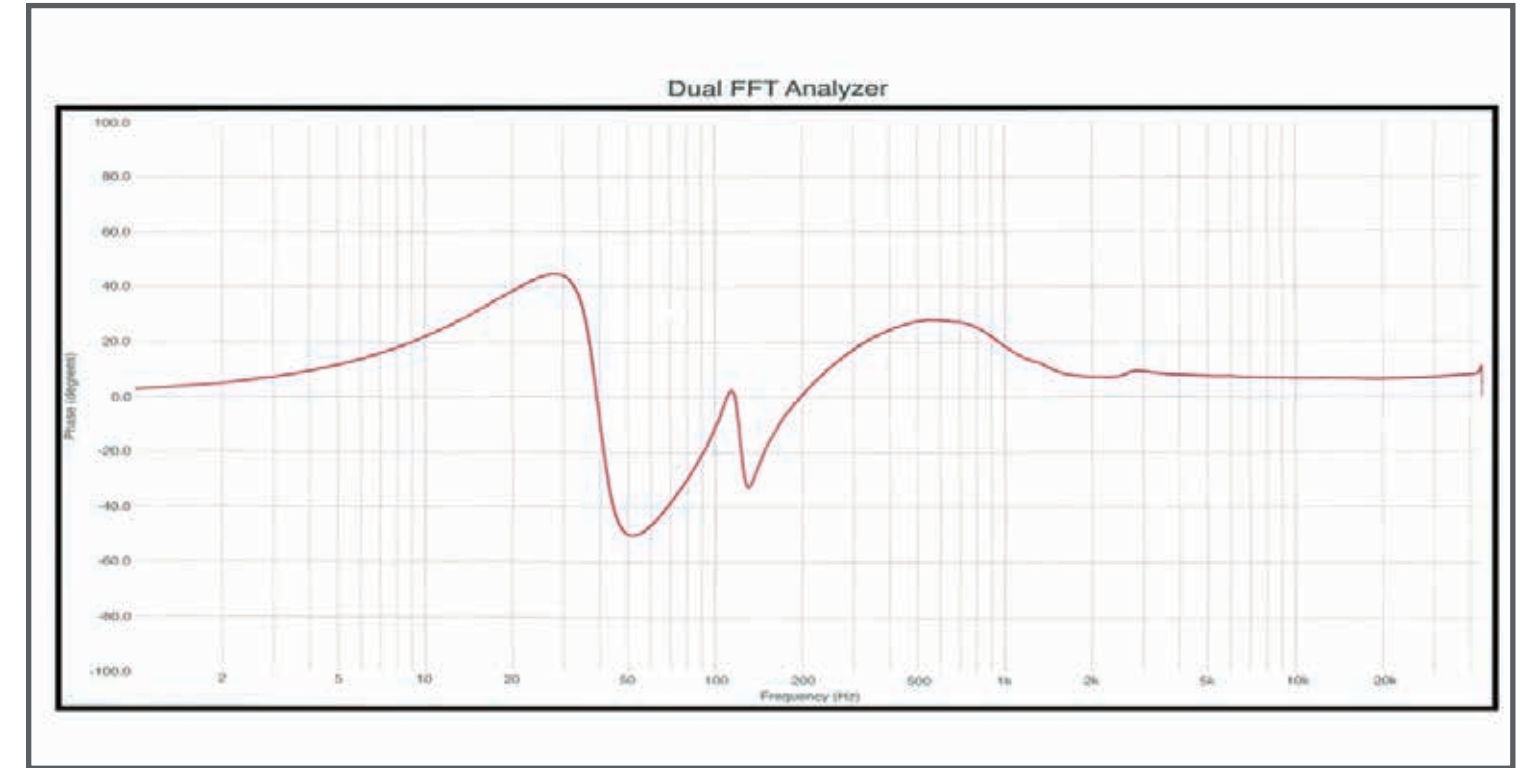



SECTION 4—TUNETOT ECOSYSTEM

Section 4.1—TuneTot ISOBase™

The Special Applications Engineering™ team spent months researching the interactions between TuneTot and the surface upon which it is installed. It quickly became clear that assumptions surrounding environmental resonance control needed to be examined. For these installations, the challenges presented are very different from what exists for a typical floor-standing loudspeaker. For those installations where TuneTot is mounted on resonant surfaces, such as on bookshelf or a desktop, Wilson engineered the optional TuneTot ISOBase. ISOBase is an interim isolation platform which is placed between the loudspeaker and the surface below. The ISOBase offers unprecedented levels of decoupling and isolation between TuneTot and the structure upon which it rests. The ISOBase is available in five different paint colors and four anodized metal finishes.

Installing ISOBase

The ISOBase is installed between TuneTot and the surface below. The isolation and time-domain spikes remain installed in TuneTot as outlined in Section 2. The ISOBase is constructed from 6060-T6 aluminum and Wilson's proprietary composites. There are indents on the X-Material top of the ISOBase that accommodate the spikes, allowing them to still function as an energy diodes. The indents are asymmetrical. When placing the ISOBase, ensure that it is oriented correctly. The

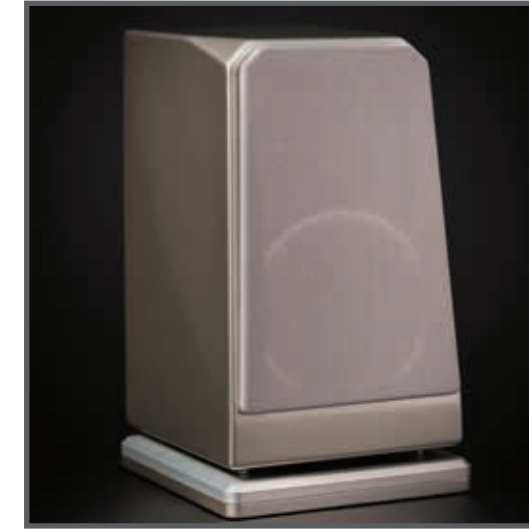
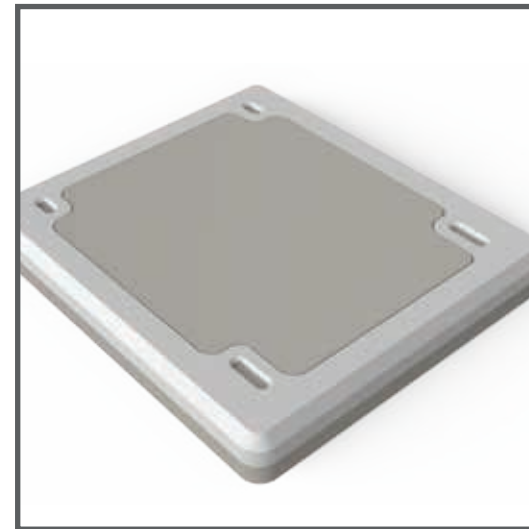

ISOBase is correctly placed with the elongated indents that are further from the base's edge placed toward the front of TuneTot.

Follow the same procedures in Section 2 for placement, time-domain correction, and leveling as you would without the ISOBase.

Section 4.2—TuneTot Grille

For those listeners who prefer a grille, one is available for TuneTot. Its low diffraction frame is individually milled from solid billets of ultra-low-resonance X-material. Acoustically transparent fabric (available in six colors) is meticulously hand stretched onto each composite frame.

The grille is installed by aligning the four pins to the four receptacles on the front baffle of TuneTot and gently pushing in until it is secure against the front baffle.

Section 4.3—TuneTot Driver Ring

Many Wilson owners prefer to listen without the grille attached. For these installations, Wilson designed an optional aluminum ring, which elegantly covers the mounting hardware securing the woofers. The ring is individually milled and is beautifully finished in a choice of four anodized colors.

The ring is secured via magnets embedded on its back surface. To install, line up the magnets with the corresponding bolts in the woofer, and carefully place the ring in the recess until it is tight against the woofer frame.



SECTION 5—WARRANTY

Section 5.1—Warranty Details

Limited Warranty

Subject to the conditions set forth herein, Wilson Audio warrants its electronics to be free of manufacturing defects in material and workmanship for the Warranty Period. The Warranty Period is a period of 90 days from the date of purchase by the original purchaser, or if both of the following requirements are met, the Warranty Period is a period of five (5) years from the date of purchase by the original purchaser:

Requirement: No later than 30 days after product delivery to the customer, the customer must complete and return the Warranty Registration Form to Wilson Audio. Alternatively, the warranty may be filled out on-line.

FAILURE TO COMPLY WITH REQUIREMENT NO. 1 WILL RESULT IN THE WARRANTY PERIOD BEING LIMITED TO A PERIOD OF 90 DAYS ONLY.

Conditions

This Limited Warranty is also subject to the following conditions and limitations. The Limited Warranty is void and inapplicable if the product has been used or handled other than in accordance with the instructions in the owner's manual, or has been abused or misused, damaged by accident or neglect or in being transported, or if the product has been tampered with or service or repair of the product has been attempted or performed by anyone other than Wilson Audio, an authorized Wilson Audio Dealer Technician or a service or repair center authorized by Wilson Audio to service or repair the product. Contact Wilson Audio at (801) 377-2233 for information on location of Wilson Audio Dealers and authorized service and repair centers. Most repairs can be made in the field. In instances where return to Wilson Audio's factory is required, the dealer or customer must first obtain a return authorization. Purchaser must pay for shipping to Wilson Audio, and Wilson Audio will pay for shipping of its choice to return the product to purchaser. A

RETURNED PRODUCT MUST BE ACCOMPANIED BY A WRITTEN DESCRIPTION OF THE DEFECT. Wilson Audio reserves the right to modify the design of any product without obligation to purchasers of previously manufactured products and to change the prices or specifications of any product without notice or obligation to any person.

Remedy

In the event that the product fails to meet the above Limited Warranty and the conditions set forth herein have been met, the purchaser's sole remedy under this Limited Warranty shall be to: (1) contact an authorized Wilson Audio Dealer within the Warranty Period for service or repair of the product without charge for parts or labor, which service or repair, at the Dealer's option, shall take place either at the location where the product is installed or at the Dealer's place of business; or (2) if purchaser has timely sought service or repair and the product cannot be serviced or repaired by the Dealer, then purchaser may obtain a return authorization from Wilson Audio and at purchaser's expense return the product to Wilson Audio where the defect will be rectified without charge for parts or labor.

Warranty Limited to Original Purchaser

This Limited Warranty is for the sole benefit of the original purchaser of the covered product and shall not be transferred to a subsequent purchaser of the product, unless the product is purchased by the subsequent purchaser from an authorized Wilson Audio Dealer who has certified the product in accordance with Wilson Audio standards and requirements and the certification has been accepted by Wilson Audio, in which event the Limited Warranty for the product so purchased and certified shall expire at the end of the original Warranty Period applicable to the product.

Demonstration Equipment

Equipment, while used by an authorized dealer for demonstration purposes, is warranted to be free of manufacturing defects in materials and workmanship for a period of five (5) years from the date of shipment to the dealer. Demo equipment needing warranty service may be repaired on-site or, if necessary, correctly packed and returned to Wilson Audio by the dealer at

dealer's sole expense. Wilson Audio will pay return freight of its choice. A returned product must be accompanied by a written description of the defect. Dealer owned demonstration equipment sold at retail within two (2) years of date of shipment to the dealer is warranted to the first retail customer to be free of manufacturing defects in materials and workmanship for the same time periods as if the product had originally been bought for immediate resale to the retail customer. Wilson Audio products are warranted for a period of 90 days, unless extended to 5 years, as provided above, by return and filing of completed Warranty Registration at Wilson Audio within 30 days after product delivery to customer and the product was professionally installed by the Wilson Audio Dealer that sold the product to the customer.

Miscellaneous

ALL EXPRESS AND IMPLIED WARRANTIES NOT PROVIDED FOR HEREIN ARE HEREBY EXPRESSLY DISCLAIMED. ANY LEGALLY IMPOSED IMPLIED WARRANTIES RELATING TO THE PRODUCT SHALL BE LIMITED TO THE DURATION OF THIS LIMITED WARRANTY. THIS LIMITED WARRANTY DOES NOT EXTEND TO ANY INCIDENTAL OR CONSEQUENTIAL COSTS OR DAMAGES TO THE PURCHASER.

Some states do not allow limitations on how long an implied warranty lasts or an exclusion or limitation of incidental or consequential damages, so the above limitations or exclusions may not apply to you. This Limited Warranty gives you specific legal rights, and you may also have other rights, which vary from state to state.