

Air Force One

Reference Turntable



TechDAS



TechDAS State-of-the-Art turntable

Analog vinyl records or discs are still the primary source used by many high-end audiophiles and music lovers around the World. To meet their needs, TechDAS has brought past know-how, the latest electronics and machining technology, and an understanding of materials science together to develop the best possible turntable for musicality and sound quality. The result is considered "State-of-the-Art". It would not be an exaggeration to say that the Air Force One is the Top-of-the-Line of turntables.

Design focus included the following:

- 1) Elimination of all unnecessary vibration and resonance
- 2) Absolute rotational accuracy and concentricity
- 3) Maximum quietness
- 4) Immunity from external vibration
- 5) Mounting flexibility for all types of tonearm
- 6) User friendliness and an elegant beauty
- 7) A choice of platter material and type
- 8) Silent, ripple free air pumps

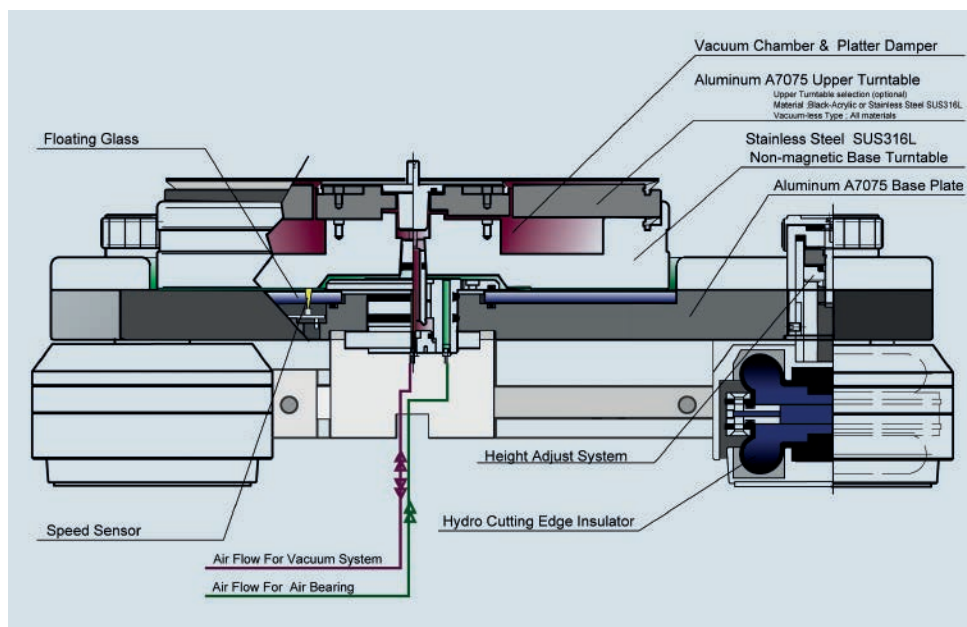

The result is an amazing level of signal to noise ratio and speed stability that used to be impossible in conventional turntables.



Main Platter (SUS316L)



A7075

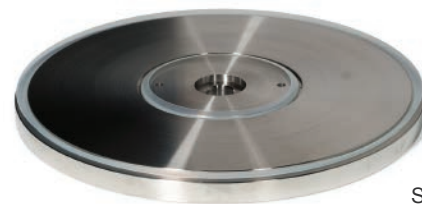

SUS316L

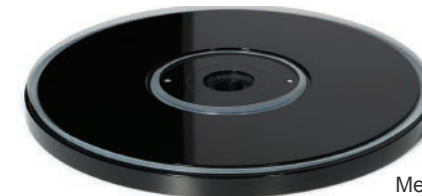

Methacrylate

Upper Platter

Unique features in the Air Force One

■ Platter

A core feature of the Air Force One is the uniquely designed platter. It consists of an air-bearing main platter and an upper sub-platter with (optional) vacuum hold-down.

Main Platter

The Main Platter is fabricated of 19kg of non-magnetic SUS316L stainless steel. The material is first forge processed (heat treated) to increase hardness and then machine-cut in a low-speed high-precision lathe to ensure a top surface with zero magnetism. The bottom surface is then mirror polished in order to ensure perfectly smooth air stream for the large air-floatation bearing. The Main Platter also incorporates an internal air-chamber of 1.1 liters. As part of the vacuum hold-down system, this large cubic volume of air brings about a characteristic damping effect that prevents resonance forming between the upper sub-platter and the main platter ensuring amazing quietness.

Upper-platter

The main platter is topped with an interchangeable upper sub-platter in a choice of materials. In addition to the choice of materials, two different types of upper platter can be chosen – with vacuum hold-down or non-vacuum hold-down – resulting in a total of six options.

A7075 :	Aircraft-grade extra super duralumin
SUS316L :	Non-magnetic hard processed stainless steel
Acrylic resin :	Black methacrylate

One upper platter of the buyer's choice is supplied with the standard order. Additional upper-platters can be ordered at the time of purchase or as optional upgrades.

■ Vacuum hold-down

The vacuum hold-down function is especially effective for the playback of warped discs. It is controlled by a "SUCTION" toggle button on the electronic control panel. Switching it to OFF momentarily reverses the air-flow to lift the disc, making removal easier. The vacuum feature minimizes resonance of the disc against the upper platter, and low-frequency oscillations caused by warped discs. An extremely thin anti-static mat is also supplied. This can be placed between the platter and disc on the vacuum hold-down models to eliminate static electricity. The special material of the mat helps in part to deliver a richer musical experience.

■ Suspension

The Air Force ONE sits on three height-adjustable feet with a hybrid air+liquid polymer suspension system. Air and a gel-type aqueous polymer are sealed in the bladder of the suspension, allowing user adjustment of the resonant frequency of the suspension system to minimize unwanted vibration.

■ Drive Belt

A custom-made non-stretchable 4mm thin flat belt is used. Uneven rotation (wow and flutter) caused by belt oscillation used to be unavoidable in conventional rubber belt drive turntables. The surface-polished polyurethane/fiber flat belt adopted by TechDAS eliminates the rubber "bounce" and this results in more stable rotation accuracy and yet allows the 30Kg platter to start-up easily and to quickly reach to rotational stability. A belt tensioner is incorporated in the motor unit for precise adjustment.

■ Motor Drive Unit

The motor unit is separate from the main chassis. In order to have the necessary stability to drive the heavy platter, A huge AC synchronous motor driven by a speed adjustable amplifier is installed in the motor chassis. Rotation speed is detected by a sensor on the bottom of the main platter and speed errors are automatically eliminated. With a platter as heavy as maximum 30Kg, maximum torque is generated until the platter reaches a steady speed and the speed locked. The driving voltage of the motor is then automatically decreased to eliminate motor-induced drive oscillation. With the almost frictionless air-bearing, stable rotation can be achieved using the moment of inertia of the massive platter. The role of driving motor after initial start-up is just to maintain a steady speed and hence only minimum torque is required. This realizes amazing quietness and still maintains absolute speed accuracy. The rotation speed is shown on a digital display on the control panel. The system allows the user to accurately adjust speed in +/- 0.1 rpm steps, which means that you can listen to music in the pitch you choose.



Motor and motor chassis

■ Chassis Structure

The turntable chassis is assembled as a three-part sandwich and weights 43kg in total. The three different aluminum layers forms a constrained-layer damping structure to eliminate ringing or resonance that may occur with a homogenous metal chassis.

Base Chassis

A5052 pure aluminum was used for tremendous strength in the base. The material also allows for a luxurious silky smooth finish.

Middle Chassis

An even stronger material, A7075 super duralumin, is used for the middle chassis. This is firmly sandwiched between the base- and upper-chassis to eliminate resonance. The material gives this part a mechanical strength that no conventional analog record player could have.

Upper Chassis

This is the visible exterior of the turntable. As with the base, A5052 aluminum is used. The top is further hard anodized to increase surface strength and resist scratches and wear on the beautiful silky-smooth finish.



Main chassis with flat and hard Glass Top

■ Tonearm Base

Up to two tonearms can be mounted on the Air Force One: a regular (9-inch or 10-inch) one at the standard right hand side is the standard specification; a second arm can be specified with an extra tone arm base at the rear left hand side. This accommodates either a 10- or 12-inch arm. A soft-and-hard combination of 12mm wood (Ebony or Brazilian Rosewood) and A7075 super duralumin provides tremendous stiffness as well as a strong connection to the main chassis to minimize phase shift that can potentially be caused by vibrations. TechDAS believes that the tonearm base is a very important factor to consider for sound improvement of record players. Every vibration mode has been analyzed in the design of the Air Force One to attain a quietness no conventional product could ever offer. (Unusual/special tonearms can also be accommodated. Please contact your TechDAS dealer or contact us directly.)

■ Power Supply/Pump Chassis

The following are housed in a separate chassis:

- 1) The motor drive power amplifier
- 2) A silent air pump unit made especially by TechDAS
- 3) DC power supply for the control functions
- 4) Switching solenoid valves to control air flow
- 5) Four separate power supplies

Motor Drive Power Amplifier

Two 50W power amplifiers generate the crystal-locked AC waveforms used to drive the AC synchronous motor. The frequency can be adjusted to vary the platter speed in 0.1 rpm steps. The driving voltage will be automatically switched to a half when the stable rotation of 33-1/3 rpm or 45 rpm is reached and speed is locked. This minimizes the influence of motor vibration and electric ripple on the platter so that the platter can have an infinitesimally silent rotation and almost infinitely even speed.

Air Pump Unit

A super-quiet motor-driven air pump sealed in a metal die-cast case is used in the Air Force One. Conventional bladder-type air pumps create noise in the air supply and this will be transmitted to the record even if the air pump is housed in a different room. A specialty rubber suspension completely eliminates vibrations and oscillation noise in the pump. Despite its tiny size, it delivers more than enough air flow for the needs of both the air bearing and the vacuum hold-down.

DC Power Supply for control circuits

The power for control buttons, LED lighting, relays, sensors and logic is provided by separate isolated power supply units. This ensures that there is no power supply influence to the minute signals from cartridge.

Air Solenoid Valves

This is part of the vacuum hold-down feature of the Air Force One. It channels airflow through the air condenser unit during vacuum operation to eliminate noise and ripples. When suction is turned off, the solenoid switches airflow from suction to discharge. This floats the disc up making removal much easier.

Four Power Supplies

Separate power supplies provide ample power in four different circuits to drive all the parts of the Air Force One.

■ Air Condenser Unit

Even with a supremely silent air pump, an air condenser plays a very important role to eliminate air ripples. The condenser corresponds to a capacitor in a DC power supply circuit. The internal structure of this chamber is made of glass to prevent any formation of secondary ripples due to wall flexure.



Air Force One with Dust Cover



Damping Table special made for Air Force One (option)

The TechDAS Air Force ONE fully utilizes modern electronics technology, the latest developments in precision CNC machining, mechanical processing, and materials science to realize a quietness previously unavailable in conventional analog players to achieve sound quality better than digital sources. That is to say, we have succeeded in reducing low frequency oscillation caused by warped discs, internal vibrations (motor vibration, driving belt resonance noise, etc.), and external vibrations to the lowest level ever.

Air Force ONE was developed with the objective of 100% retrieval of the music that is engraved in the groove of the analog disc. We take pride in having reached the "State of the Art" in analog record music reproduction.

Specifications

Drive System		Belt Drive, Surface polished polyurethane fiber flat belt
Platter	Main Platter	SUS316L Forged and non-magnetism processed. Weight 19 kg
	Upper Platter	a choice of - A7075 (3.5 kg), SUS316L (10 kg) Methacrylate (1.5 kg)
Motor		AC synchronous motor. Rotating speed controlled by DC amplifier. Motor weight 6.6 kg
Chassis		Three different material sandwiched structure. Chassis weight 43kg
Rotation Speed		33-3/1 rpm / 45 rpm Precise speed adjustment function.
Wow & Flutter		below 0.03% (W.R.M.S)
Minimum Dimensions for setting up		600 (W) x 450 (D) mm
Total Weight		79 kg
Power Supply Unit		Power consumption: 60W Dimension and weight : 430(W) x 150(H) x 240(D) mm, 10kg Operation voltage: 100 / 120 / 220 / 240 V (50 / 60 Hz)
Air Condenser Unit		Dimension: 260 (W) x 160 (H) x 240 (D) mm 4kg
Accessories Supplied		Tonearm Base Board x 1 (drilled for specified tonearm) Dust Cover x 1 AC Cable x 1
Optional Items & Accessories		Special Damping Table made for Air Force One Second Tonearm Base Board Tonearm Base Board for supplement (for 1st and/or 2nd tonearms) Upper Platter for supplement (A7075/SUS316L/Methacrylate)