

auditor M

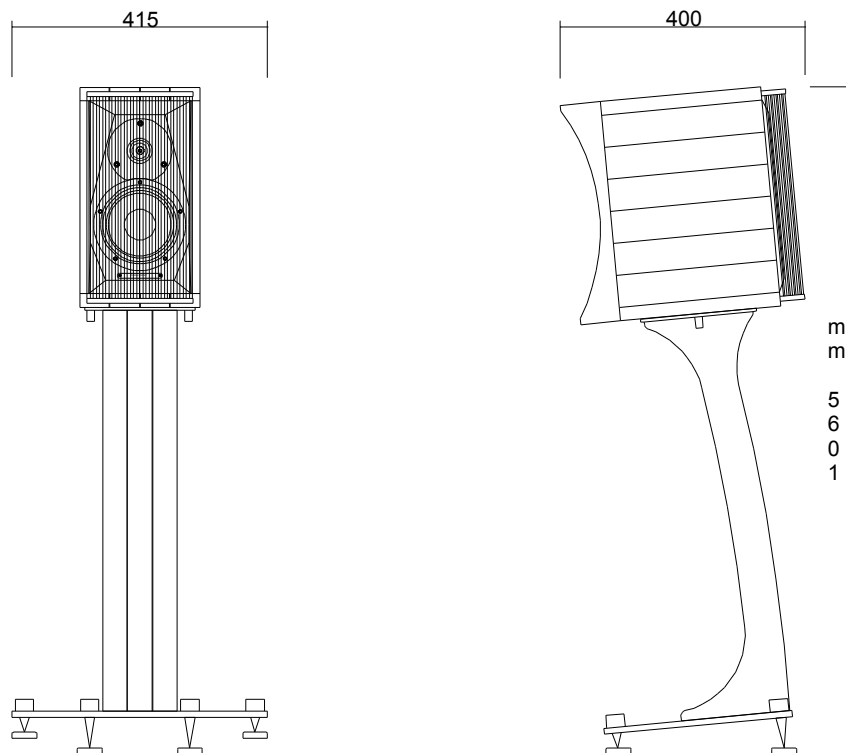

SYSTEM: 2 way vented box loudspeaker.

CABINET: Lute shape design, combination of sandwich construction, obtained using 20 hand selected wood layers and solid maple, quality graded and oriented for carefully optimized resonances and standing waves control.

TWEETER: 25 mm ultra dynamic ring radiator-driver, with dual toroidal wave-guide.

MIDRANGE: 150 mm cone driver with Symmetric Drive Motor System and selected black wood fiber cone, high resolution, treated for break-up control.
Dynamic linear suspension.

CROSS-OVER: Non-resonant first order design, optimized phase characteristics for optimal space/time performance, crossing point 2500Hz

FREQUENCY RESPONSE: 50 Hz – 30.000 Hz, tuning ports included.

SENSITIVITY: 88 db SPL (2.83 V/1m).

NOMINAL IMPEDANCE: 4 ohms.

POWER HANDLING: 40W – 150W, without clipping.

FINISH: Natural maple multicoated with medium gloss ecologically sensitive lacquer.

DIMENSIONS: 202 x 365 x 353 mm (WxDxH). **WEIGHT:** 18.4 Kg per pair – net weight/ 22.3 Kg per pair – shipping weight.

OPTIONAL DEDICATED STAND: 415 x 310 x 710 mm (WxDxH). **WEIGHT:** 22.6 Kg per pair – net weight/ 26.4 Kg per pair – shipping weight.

TOTAL DIMENSIONS: 415 x 400 x 1065 mm (WxDxH).