



KAV-2250

Stereo Power Amplifier

KAV-3250

Three-channel Power Amplifier

Instructions for Use

Owner's Reference

KAV–2250
Stereo Power Amplifier
KAV–3250
Three-channel Power Amplifier
Instructions for Use

Krell Industries, Inc.
45 Connair Road
Orange, CT 06477-3650 USA
TEL 203-799-9954
FAX 203-891-2028
E-MAIL krell@krellonline.com
WEBSITE <http://www.krellonline.com>

v 01.2



This product complies with the EMC directive (89/336/EEC) and the low-voltage directive (73/23/EEC).

WARNINGS

The amplifier must be placed on a firm, level surface where it is not exposed to dripping or splashing.

The ventilation grids on the top and bottom of the amplifier must be unobstructed at all times during operation. Do not place flammable material above or beneath the amplifier.

Contact your authorized Krell dealer, distributor, or Krell before using any devices designed to alter or stabilize the AC power for the KAV–2250 and the KAV–3250.

Before connecting the KAV–2250 and the KAV–3250, make sure the amplifier is turned off and any output device (such as a preamplifier) is in mute or stand-by mode. Make sure all cable terminations are of the highest quality and free from frayed ends, short circuits, or cold solder joints.

Use only one input to each amplifier channel at a time.

Make sure that only one switch on an input switch bank is in the up (on) position at one time.

THERE ARE NO USER SERVICEABLE PARTS INSIDE ANY KRELL PRODUCT.

Please contact your authorized Krell dealer, distributor, or Krell if you have any questions not addressed in this reference manual.

This product is manufactured in the United States of America. Krell® is a registered trademark of Krell Industries, Inc., and is restricted for use by Krell Industries, Inc., its subsidiaries, and authorized agents. Multi Amp Throughput™ and Krell Current Mode™ are trademarks of Krell Industries, Inc. All other trademarks and tradenames are registered to their respective companies.

Contents

Page

INTRODUCTION	1
DEFINITION OF TERMS	2
UNPACKING	4
PLACEMENT	5
AC Power Guidelines	5
FRONT PANEL DESCRIPTION	7
BACK PANEL DESCRIPTION	9
CONNECTING THE AMPLIFIER TO YOUR SYSTEM	11
Input and Output Connections	11
AMPLIFIER OPERATION	13
On/Off and Operation	13
Using a Dedicated Wall Switch	13
TROUBLESHOOTING SYSTEM NOISE	14
RECONFIGURATION OPTIONS FOR THE KAV–2250 AND KAV–3250	15
To Safely Access the Input Switch Banks	15
Amplifier Factory Default Settings	18
Reconfiguring the Amplifier for MAT Operation	18
Reconfiguring the Amplifier for Bridged Operation	21
Example of a Connection Scenario: Multi-power Mode	22
QUESTIONS AND ANSWERS	23
WARRANTY	24
RETURN AUTHORIZATION PROCEDURE	25
SPECIFICATIONS	
KAV–2250	26
KAV–3250	27

Illustrations

Page

FIGURE 1	The KAV–2250 Front Panel	6
FIGURE 2	The KAV–3250 Front Panel	6
FIGURE 3	The KAV–2250 Back Panel	8
FIGURE 4	The KAV–3250 Back Panel	8
FIGURE 5	Amplifier Factory Default Settings	16
FIGURE 6	Reconfiguring the KAV–2250 for MAT Operation	17
FIGURE 7	Reconfiguring the KAV–3250 for MAT Operation	17
FIGURE 8	Reconfiguring the KAV–2250 for Bridged Operation	20
FIGURE 9	Reconfiguring the KAV–3250 for Bridged Operation	20

Introduction

Thank you for your purchase of the Krell KAV–2250 Stereo Power Amplifier or the KAV–3250 Three-channel Power Amplifier.

The KAV–2250 and KAV–3250 amplifiers provide substantial two- and three-channel output power that delivers realistic music reproduction at an exceptional value. These amplifiers can be customized with two optional system configurations: Multi Amp Throughput (MAT) and bridged operation. These configurations provide a wider range of power outputs and connection options. Both the KAV–2250 and KAV–3250 amplifiers have balanced and single-ended inputs, for complete compatibility with other components. The KAV–2250 and KAV–3250 amplifiers can be operated using the 12 VDC trigger on other components. Either amplifier integrates seamlessly into home theater or whole-house systems.

This reference manual contains important information on placement, installation, and operation of the KAV–2250 and KAV–3250 amplifiers. Please read this information carefully. A thorough understanding of these details helps ensure satisfactory operation and long life for your amplifier and related system components.

Definition of Terms

Following are the definitions of key terms used in your owner's reference manual.

CONFIGURATIONS

Bridging

A method of linking two amplifier channels by distributing the speaker load between the positive binding posts. Bridging the channels quadruples the power rating at 8 Ohms. Bridged configurations should not be used with loads under 4 Ohms.

Krell Multi Amp Throughput (MAT)

An internal configuration option that sends the same music signal to all amplifier channels using one balanced or single-ended connection. MAT reduces installation complexity and cabling requirements in systems containing multiple amplifiers. MAT also allows a variety of connection scenarios, including powering loudspeakers that have two sets of binding posts and independently powering multiple pairs of stereo loudspeakers to extend the listening environment throughout your home.

INPUT AND OUTPUT CONNECTIONS

Balanced

A symmetrical input or output circuit that has equal impedance from both input terminals to a common ground reference point. The industry standard for professional and sound recording installations, balanced connections have 6 dB more gain than single-ended connections and allow the use of long interconnect cables. Balanced connections are completely immune to induced noise from the system or the environment.

Single-ended

A two-wire input or output circuit. Use care when using single-ended connections as the ground connection is made last and broken first. Turn the system off prior to making or breaking single-ended connections. Single-ended connections are not recommended for connections requiring long cable runs.

Definition of Terms, continued

OPERATION

Off

When the back panel power switch is in the down (off) position and the red stand-by LED turns off, the component is off.

Stand-by Mode

When the AC power cord is plugged into the wall and the back panel power switch is in the up (on) position, the red stand-by LED illuminates, indicating that the component is in stand-by mode. This low power consumption status keeps the audio and regulator circuits at idle. Krell recommends leaving the component in the stand-by mode when it is not playing music.

Operational Mode

From the stand-by mode, when the power button on the front panel is pressed and the blue power indicator illuminates, the component is in the operational mode and ready to play music.

TECHNOLOGY

Krell Current Mode

A proprietary Krell circuit topology in which the audio gain stages of a component operate in the current rather than voltage domain. This unique technology provides the component with exceptional speed and a wide bandwidth.

Unpacking

1. Open the shipping box and remove the top layer of foam. You see these items:

- 1 amplifier unit (packed in foam end-caps)
- 1 IEC connector (AC power) cord
- 1 12 VDC output (12 V trigger) cable
- 1 T-15 Torx wrench
- KAV-2250 fuses:
 - 2 AGC-12 (12-amp)
 - or
- KAV-3250 fuses:
 - 3 AGC-12 (12-amp)
- 1 packet containing the owner's reference manual and the warranty registration card.

2. Locate the cutouts in the foam end caps.

3. Slip hands under cutouts and lift the amplifier straight out of the box.

4. Place the amplifier in a safe location and remove the protective plastic wrapping.

Notes

If any of these items are not included in the shipping box, please contact your authorized Krell dealer, distributor, or Krell for assistance.

*Save all packing materials. If you ship your amplifier in the future, repack the unit in its original packaging to prevent transit damage. See **Return Authorization Procedure**, on page 25, for more information.*

The KAV-2250 weighs 64 lbs. and the KAV-3250 weighs 68 lbs. It may be more convenient for two people to lift the amplifier out of the shipping box.

Placement

Before you integrate your new amplifier into your system, please review the following guidelines to choose the location for the component. This will facilitate a clean, trouble-free installation.

The amplifier requires at least two inches (5 cm) of clearance on each side and at least two inches (5 cm) of clearance above and below the component to provide adequate ventilation.

The amplifier does not require any type of special rack or cabinet for installation. For the dimensions of your amplifier see **Specifications**, on pages 26 and 27.

Place the amplifier as close to the loudspeakers as possible and keep the loudspeaker cable length to a minimum. Loudspeaker cable adds impedance to the load the amplifier must drive, regardless of the cable's gauge. Krell amplifiers drive the lowest impedances with ease, but long loudspeaker cables reduce the maximum power that is delivered to the loudspeakers.

AC POWER GUIDELINES

Krell recommends operating the amplifier from a dedicated 15-amp AC power line. Please contact your authorized Krell dealer, distributor, or Krell before using any devices designed to alter or stabilize the AC power for the KAV-2250 and KAV-3250.

Power Cord

The KAV-2250 and KAV-3250 should be operated only with the power cord supplied.

Figure 1 The KAV-2250 Front Panel

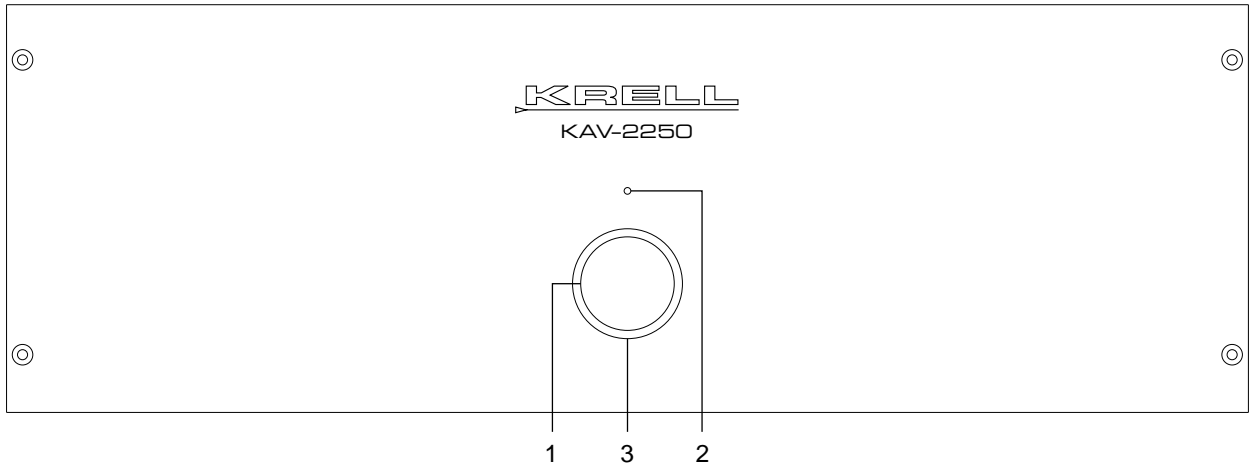
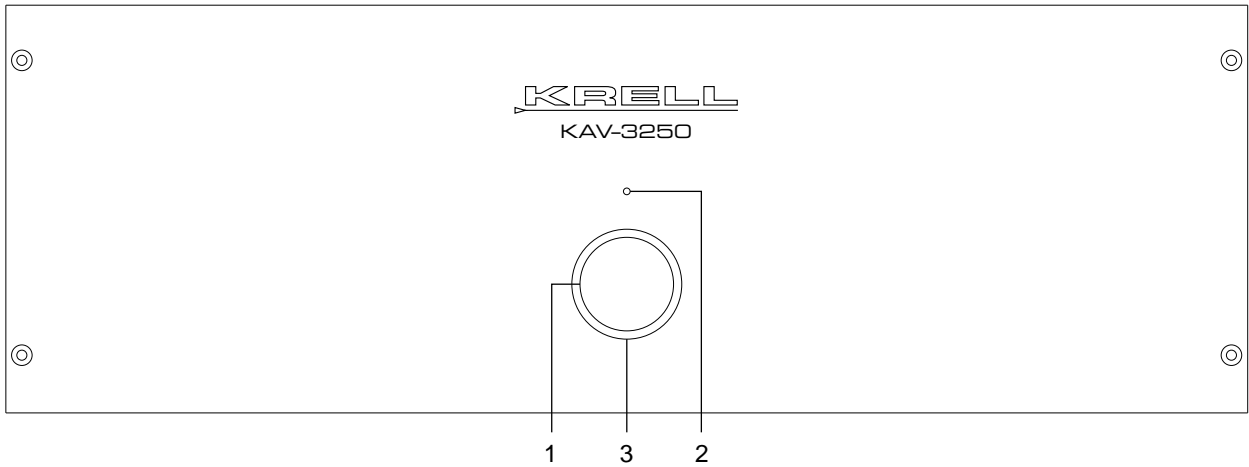

Figure 2 The KAV-3250 Front Panel



- 1 Power Button
- 2 Stand-by LED
- 3 Power Indicator

Front Panel Description

See Figures 1 and 2 on page 6

The front panel on the KAV–2250 and the KAV–3250 provides power on and indicates operating status.

1 Power Button

Use this button to switch the power between the stand-by and the operational modes and also to switch the 12 VDC output (12 V trigger) on and off.

2 Stand-by LED

The red stand-by LED illuminates when the AC power cord is plugged into the wall and the back panel power switch is in the up (on) position.

3 Power Indicator

The blue power indicator illuminates when the amplifier is in the operational mode.

Figure 3 The KAV-2250 Back Panel

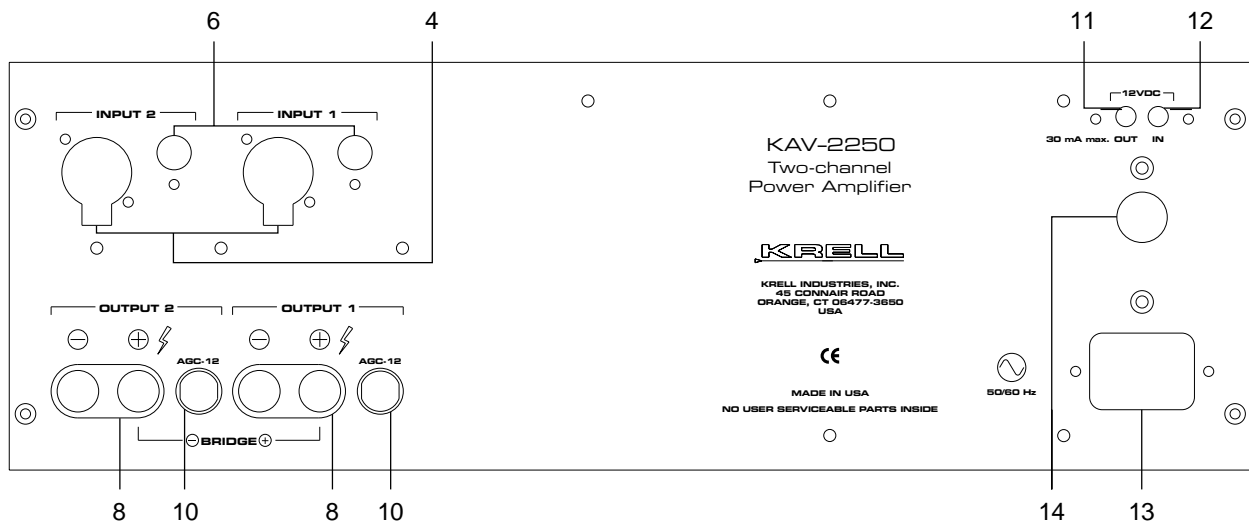
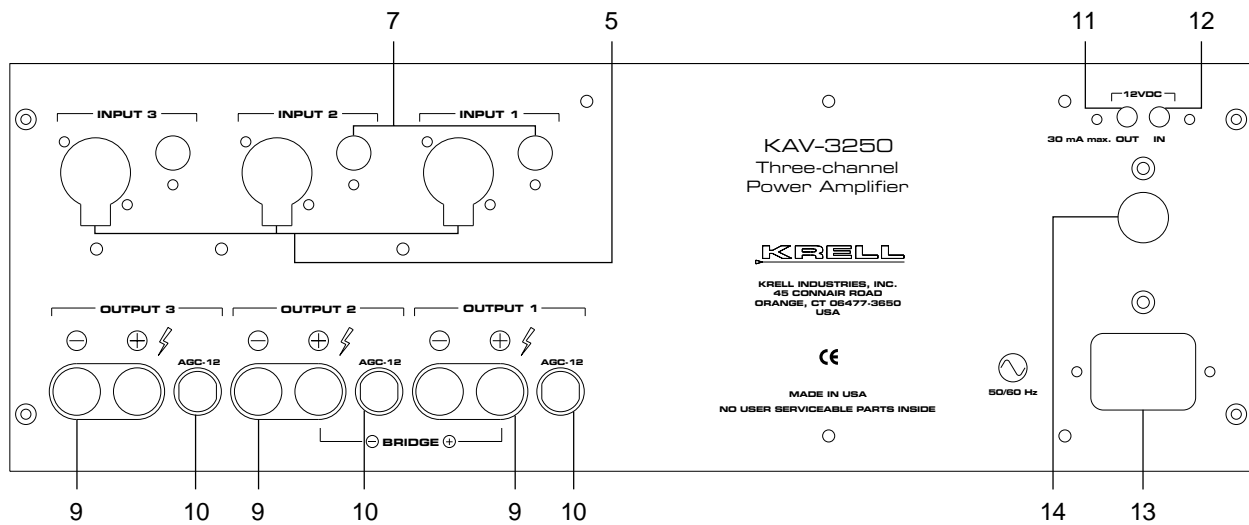

Figure 4 The KAV-3250 Back Panel



Balanced Inputs

4 Inputs 1-2

5 Inputs 1-3

Single-Ended Inputs

6 Inputs 1-2

7 Inputs 1-3

Amplifier Channel

Outputs

8 Outputs 1-2

9 Outputs 1-3

Fuses

10 AGC-12 Fuses

Remote Connections

11 12 VDC Remote Power Out

12 12 VDC Remote Power In

Power

13 IEC Power Connector

14 Back Panel Power Switch

Back Panel Description

See *Figures 3 and 4 on page 8*

The back panel on the KAV–2250 and the KAV–3250 provides connections for all inputs and outputs, remote connection input and output links, and the AC power supply. See *Reconfiguration Options for the KAV–2250 and the KAV–3250*, on pages 15-22, for information on optional system configurations and amplifier channel output connections.

Balanced Inputs

4 Inputs 1-2

The KAV–2250 has two channel inputs for output devices with balanced XLR connectors.

5 Inputs 1-3

The KAV–3250 has three channel inputs for output devices with balanced XLR connectors.

Single-ended Inputs

6 Inputs 1-2

The KAV–3250 has two channel inputs for output devices with single-ended RCA connectors.

7 Inputs 1-3

The KAV–3250 has three channel inputs for output devices with single-ended RCA connectors.

Amplifier Channel Outputs

8 Outputs 1-2

The KAV–2250 has two amplifier channel outputs. The loudspeaker binding post terminals accept spade lugs, bare wire, or pins. Use the red terminal for the positive connection and the black terminal for the negative connection.

9 Outputs 1-3

The KAV–3250 has three amplifier channel outputs. The loudspeaker binding post terminals accept spade lugs, bare wire, or pins. Use the red terminal for the positive connection and the black terminal for the negative connection.

IMPORTANT

Tighten loudspeaker binding posts by hand only.

Back Panel Description, continued

Fuses

10 AGC-12 Fuses

The AGC-12 Amp loudspeaker fuses protect the amplifier against short circuits at the amplifier outputs.

Back Panel Remote Connections

11 12 VDC Remote Power Out

The amplifier is equipped with an output that sends 12 VDC power on/off (12 V trigger) signals to other Krell components and other devices that incorporate a 12 V trigger.

12 12 VDC Remote Power In

The amplifier is equipped with an input that receives 12 VDC power on/off (12 V trigger) signals from other Krell components and other devices that incorporate a 12 V trigger. This allows you to turn the amplifier on and off using a Krell or other component in a custom installation.

Notes

When the component is in the operational mode, the 12 VDC Out provides 12 V of DC output. When the component is in the stand-by mode or off, the DC output is 0 V.

12 VDC Out (12 V trigger) current is limited to 30 mA.

Consult the owner's manual of each component used in a custom installation to take full advantage of the amplifier's remote capability.

Power

13 IEC Power Connector

The amplifier is equipped with a standard female IEC power connector, for use with the provided AC power cord.

14 Back Panel Power Switch

Use this switch to turn the amplifier from off to the stand-by mode.

Connecting the Amplifier to Your System

INPUT AND OUTPUT CONNECTIONS

The amplifier is equipped with balanced and single-ended inputs.

Krell recommends using balanced interconnect cables. Balanced interconnect cables not only can minimize sonic loss but are also immune to induced noise, especially with installations using long cables. Balanced connections have 6 dB more gain than single-ended connections. When level matching is critical, please keep this gain value in mind.

The amplifier is shipped with shorting pins in the XLR inputs. These pins should remain in the XLR inputs if the amplifier is operating in the single-ended mode. When the shorting pin is inserted, pins 1 (lower left) and 3 (top) are shorted together. Remove the shorting pins to connect the amplifier for balanced operation.

The XLR pin configuration is described below:

Pin 1 Shield (ground)

Pin 2 Non-inverting (hot) (0°)

Pin 3 Inverting (cold) (180°)

Follow these steps to connect the amplifier to your system.

1. Make sure all power sources and components are off before connecting inputs and outputs.
2. Neatly organize the wiring between the amplifier and all system components. Separate AC wires from audio cables to prevent hum or other unwanted noise from being introduced into the system.
3. Connect the interconnect cables from your output device to the amplifier inputs using the balanced or single-ended inputs located on the back panel: (4) and (6) on the KAV-2250 or (5) and (7) on the KAV-3250. The balanced inputs use three-pin XLR connectors; the single-ended inputs use RCA connectors.

IMPORTANT

Use only one input to each amplifier channel at a time.

Connecting the Amplifier, continued

4. Connect the loudspeaker cables to the amplifier channel output binding posts located on the back panel, (8) on the KAV–2250 or (9) on the KAV–3250.

The binding post terminals accept spade lugs, bare wire, or pins. Use the red terminal for the positive connection and the black terminal for the negative connection.

IMPORTANT

Tighten loudspeaker binding posts by hand only.

5. Plug the end of the AC power cord into the IEC power connector.

The amplifier is now ready for operation. See ***Amplifier Operation***, on page 13. You can also reconfigure the amplifier for Multi Amp Throughput or bridged operation. See ***Reconfiguration Options for the KAV–2250 and the KAV–3250***, on page 15.

Amplifier Operation

ON/OFF AND OPERATION

When powering up your system, turn amplifiers **on last**. When powering down your system, turn amplifiers **off first**. The procedures for amplifier operation follow.

1. Plug the AC power cord into the AC power wall receptacle.
2. Push the back panel power switch (14) up (on). The red stand-by LED (2) illuminates.
3. Press the power button (1) on the front panel. The blue power indicator (3) illuminates and you hear a click.

There will be a brief delay before the component can be put in the operational mode after the back panel power switch is first pushed up.

Krell recommends leaving the amplifier in the stand-by mode unless you will not be playing music for a long time.

IMPORTANT

Always turn the amplifier off before changing input connections, and mute or fully attenuate the preamplifier level when switching sources.

The amplifier has tremendous reserves of power and safely drives loudspeakers to extremely high sound pressure levels. However, use care when setting high playback levels and lower the volume level at any sign of loudspeaker distress.

USING A DEDICATED WALL SWITCH

The amplifier can also be powered on from an AC wall receptacle with a dedicated switch, rather than from the front panel power button. Please contact your authorized Krell dealer, distributor, or Krell for more information before you connect the amplifier to a dedicated AC wall outlet with a switch.

Troubleshooting System Noise

When you mix and match high-performance audio components, each with its own ground potential, a low frequency hum may occur in one or all loudspeakers. If this happens when you place the amplifier into your system, follow these simple troubleshooting steps:

1. Check that all input and output connections are of sound construction.
2. With the amplifier off, remove all the interconnect cables, then turn the amplifier on. If the hum disappears, turn the amplifier off and reinsert one of the interconnect cables. Turn the amplifier back on.
3. If the hum reappears with the interconnect cable reinserted, the cable may need to be replaced. Turn the amplifier off and connect a different interconnect cable to the same location. Turn the amplifier back on.
4. If the hum disappears with the interconnect cable reinserted, that cable most likely is sound.
5. Turn the amplifier off, disconnect the interconnect cable, and re-connect one of the other interconnect cables.
6. Repeat steps 3 through 5 until you have checked each interconnect cable individually.
7. If all the interconnect cables appear to be sound, and if you still have hum, you may be experiencing a ground loop. Please contact your authorized Krell dealer, distributor, or Krell for suggestions on how to eliminate it.

Reconfiguration Options for the KAV–2250 and KAV–3250

There are a number of options for reconfiguring the amplifier output:

Multi Amp Throughput (MAT) is an internal connection option for the amplifier that lets you send the same music signal to all amplifier channels using one balanced or single-ended connection. MAT reduces installation complexity and cabling requirements in systems containing multiple amplifiers.

Bridging allows you to reconfigure two channels to operate as one combined amplifier channel. The bridged amplifier channels deliver 1,000 Watts into an 8 Ohm load. The remaining unbridged amplifier channel on the KAV–3250 can be connected to a separate loudspeaker.

To reconfigure the amplifier for MAT or for bridged operation you need to remove the top cover of the amplifier and access the input switch banks.

IMPORTANT

*Removing the cover of the amplifier to reconfigure for MAT or for bridged operation is the **ONLY** instance you are authorized to remove the cover of **ANY** Krell component without voiding your Warranty. For more information on product limitations and restrictions, see **Warranty**, on page 24.*

TO SAFELY ACCESS THE INPUT SWITCH BANKS

Before reconfiguring the amplifier, please read the following important instructions to safely remove the amplifier cover and access the input switch banks to reconfigure the KAV–2250 or KAV–3250.

Tool needed: T-15 Torx wrench

1. Unplug the AC power cord from AC power.
2. Krell suggests removing jewelry before reconfiguring your amplifier. Rings, necklaces, bracelets, and other metal jewelry can conduct an electrical charge.
3. Using the T-15 Torx wrench, remove the 12 screws that secure the amplifier cover.
4. Carefully remove the cover.
5. Locate the green input circuit board, which has white input switches and red input switch banks, at the rear of the amplifier

Figure 5 Amplifier Factory Default Settings

KAV-2250

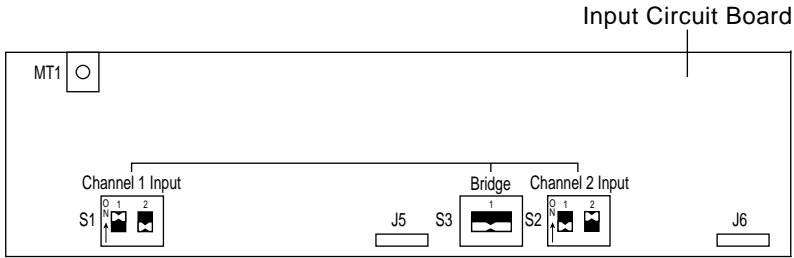

KAV-3250

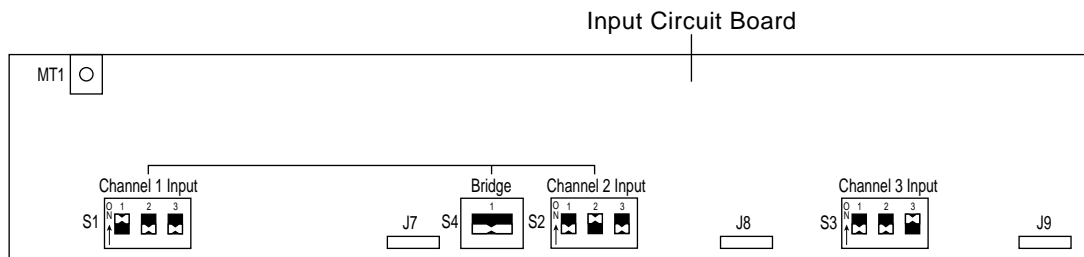

 Switch Up (On)

 Switch Down (Off)

 Bridge Switch Up (On)

 Bridge Switch Down (Off)

 KAV-2250 Input Switch Bank

 KAV-3250 Input Switch Bank

Figure 6 Reconfiguring the KAV-2250 for MAT Operation

**Send One Input Signal
to Both Output Channels via Input 1**

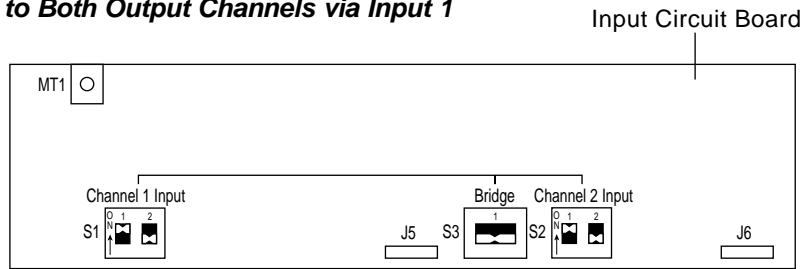
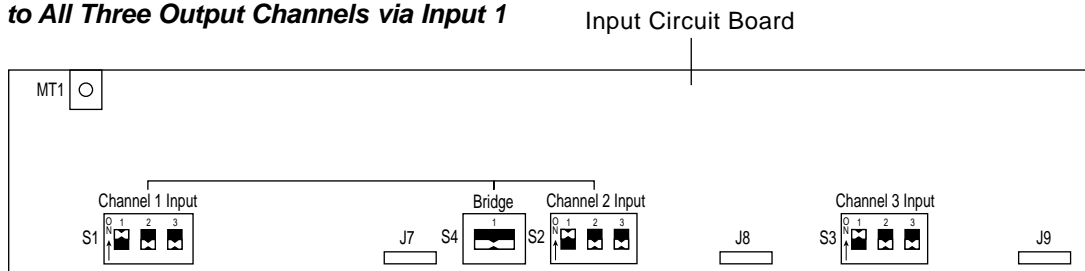



Figure 7 Reconfiguring the KAV-3250 for MAT Operation

**Send One Input Signal
to All Three Output Channels via Input 1**





 Switch Up (On)

 Switch Down (Off)

 Bridge Switch Up (On)

 Bridge Switch Down (Off)

 KAV-2250 Input Switch Bank

 KAV-3250 Input Switch Bank

Reconfiguration Options, continued

Accessing the Input Switch Banks, continued

6. Reconfigure your amplifier, using the scenarios described below.
7. After the component is configured, replace the cover and, using the T-15 Torx wrench, secure all 12 cover screws.

IMPORTANT

Operating the amplifier without the cover properly replaced and secured may void your Warranty.

AMPLIFIER FACTORY DEFAULT SETTINGS

See Figure 5 on page 16

The KAV–2250 amplifier is shipped with input switch banks set to the following factory defaults:

1. For input switch bank 1: switch 1 up (on), switch 2 down (off).
2. For input switch bank 2: switch 1 down (off), switch 2 up (on).

The KAV–3250 amplifier is shipped with input switch banks set to the following factory defaults:

1. For input switch bank 1: switch 1 up (on), other switches down (off).
2. For input switch bank 2: switch 2 up (on), other switches down (off).
3. For input switch bank 3: switch 3 up (on), other switches down (off).

RECONFIGURING THE AMPLIFIER FOR MAT OPERATION

Reconfiguring the KAV–2250 for MAT: Send One Input Signal to Both Output Channels via Input 1

See Figure 6 on page 17

To send the signal from a source device connected to input 1:

1. Push switch 1 up (on) for both input switch banks.
2. Push switch 2 down (off) for both input switch banks.

Reconfiguration Options, continued

Reconfiguring the KAV–2250 for MAT: Send One Input Signal to Both Output Channels via Input 2

Not illustrated

To send the signal from a source device connected to input 2:

1. Push switch 2 up (on) for both input switch banks.
2. Push switch 1 down (off) for both input switch banks.

Reconfiguring the KAV–3250 for MAT: Send One Input Signal to All Three Output Channels via Input 1

See Figure 7 on page 17

To send the signal from a source device connected to input 1:

1. Push switch 1 up (on) for all input switch banks.
2. Push switches 2 and 3 down (off) for all input switch banks.

Reconfiguring the KAV–3250 for MAT: Send One Input Signal to All Three Output Channels via Any Input

Not illustrated

You can send the signal from any of the inputs, depending on your preference, for example:

To send the signal from a source device connected to input 2:

1. Push switch 2 up (on) for all input switch banks.
2. Push switches 1 and 3 down (off) for all input switch banks.

or

To send the signal from a source device connected to input 3:

1. Push switch 3 up (on) for all input switch banks.
2. Push switches 1 and 2 down (off) for all input switch banks.

Figure 8 Reconfiguring the KAV–2250 for Bridged Operation

Bridge Channel 1 and 2

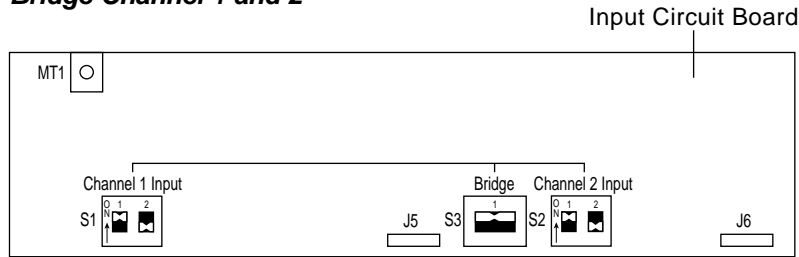
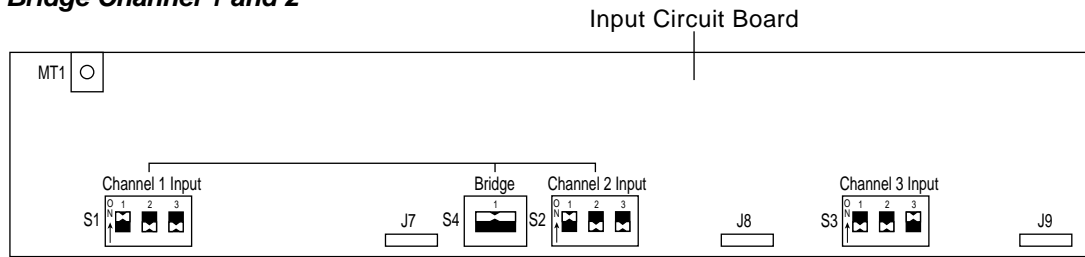



Figure 9 Reconfiguring the KAV–3250 for Bridged Operation

Bridge Channel 1 and 2





 Switch Up (On)

 Switch Down (Off)

 Bridge Switch Up (On)

 Bridge Switch Down (Off)

 KAV–2250 Input Switch Bank

 KAV–3250 Input Switch Bank

Reconfiguration Options, continued

Connecting the Amplifier Reconfigured for MAT

1. Connect the cable from your source device to the balanced or single-ended input you have selected to receive the signal. (For example, if you use the switch settings shown in Figure 6 your source device is connected to input 1.)
2. Connect each amplifier channel output to a separate loudspeaker.

RECONFIGURING THE AMPLIFIER FOR BRIDGED OPERATION

Reconfiguring the KAV–2250 or the KAV–3250 to Bridge Channels 1 and 2

See Figures 8 and 9 on page 20

To send the signal from a source device connected to input 1, with channels 1 and 2 bridged:

1. For input switch bank 1, push switch 1 up (on).
2. For input switch bank 2, push switch 1 up (on).
3. Push the bridge switch up (on) between input switch banks 1 and 2.

Notes

Amplifier channels 1 and 2 may be bridged. Channel 3 on the KAV–3250 cannot be bridged.

The unbridged channel on the KAV–3250 may be connected to a separate loudspeaker for normal operation.

Connecting the Amplifier Reconfigured for Bridged Operation

1. Connect the cable from the input device to the balanced or single-ended input you have selected to receive the signal.
2. Connect the positive loudspeaker lead to the red binding post on the corresponding amplifier channel marked “BRIDGE +.” Connect the negative loudspeaker lead to the red binding post on the amplifier channel marked “BRIDGE -.”

IMPORTANT

Tighten binding posts by hand only.

Reconfiguration Options, continued

EXAMPLE OF A CONNECTION SCENARIO: MULTI-POWER MODE

Multi-power mode is a possible connection scenario that uses the amplifier's Multi Amp Throughput (MAT) feature. With multi-power mode, you can reconfigure the amplifier to independently power multiple pairs of stereo loudspeakers and extend the listening environment throughout your home. When the amplifier is reconfigured for MAT, each channel powers an individual loudspeaker, with one amplifier dedicated to driving outputs to the left loudspeakers and one amplifier driving outputs to the right loudspeakers.

The diagram below illustrates a multi-power mode connection scenario:

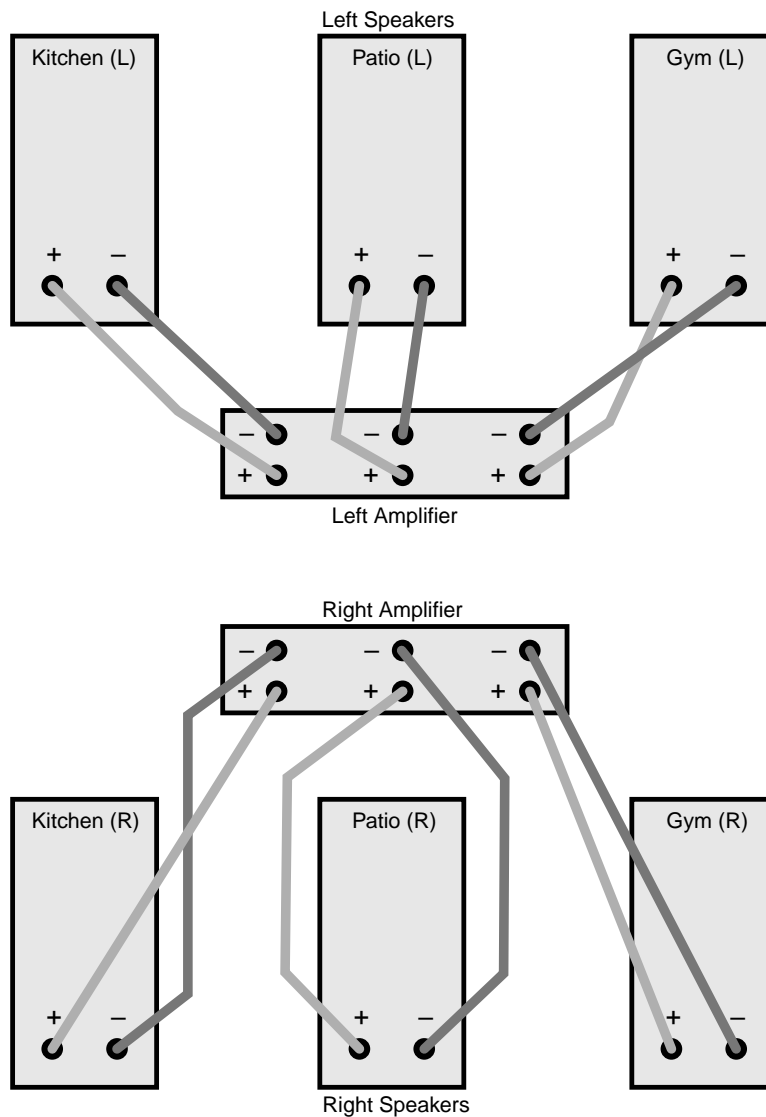

Questions and Answers

Q. Should I turn the amplifier off when not playing music?

A. No. Leave the amplifier in stand-by when not playing music. The stand-by mode avoids cold starts as well as minimizes heat output and power consumption. Krell recommends turning the amplifier off if you plan to be away for a period of time, for example, on vacation. See ***Amplifier Operation***, on page 13.

Q. When I turn the amplifier on there is a loud hum through the loudspeakers. What should I do?

A. When a new component is introduced, a low frequency hum may occur in one or both loudspeakers. Check that all input and output connections and cables are of sound construction. See ***Troubleshooting System Noise***, on page 14. If the connections and cables are sound, you may be experiencing a ground loop. This can often be easily eliminated. Please contact your authorized Krell dealer, distributor, or Krell for suggestions.

Q. When I connect the amplifier to my system using the single-ended inputs, a loud buzz comes from my loudspeakers. What is it?

A. Check that the shorting pins for the amplifier are inserted into the XLR inputs (the unit is shipped with the pins in place). When using the single-ended inputs, the shorting pins must be inserted between pins 1 and 3 to keep external noise from corrupting the signal. For more information, see ***Connecting the Amplifier to Your System***, on page 11.

Q. Can I bridge all the channels on my KAV–3250 amplifier?

A. No. You can bridge two of the amplifier's channels: 1 and 2. Channel 3 cannot be bridged.

Q. Will I be able to use the amplifier without reconfiguring the channels for MAT or bridged operation?

A. Yes. The amplifier is shipped from the factory ready to play music. The default settings, see ***Figure 5***, on page 16, allow you to connect each amplifier channel output to a separate loudspeaker. MAT and bridging reconfigurations are optional.

Warranty

This Krell product has a limited warranty of five years for parts and labor on circuitry. Should this product fail to perform at any time during the warranty, Krell will repair it at no cost to the owner, except as set forth in this warranty.

The warranty does not apply to damage caused by acts of God or nature.

The warranty on this page shall be in lieu of any other warranty, expressed or implied, including, but not limited to, any implied warranty of merchantability or fitness for a particular purpose. There are no warranties which exceed beyond those described in this document. If this product does not perform as warranted herein, the owner's sole remedy shall be repair. In no event will Krell be liable for incidental or consequential damages arising from purchase, use, or inability to use this product, even if Krell has been advised of the possibility of such damages.

Proof of purchase in the form of a bill of sale or receipted invoice substantiating that the unit is within the warranty period must be presented to obtain warranty service. The warranty begins on the date of the original retail purchase, as noted on the bill of sale or receipted invoice from an authorized Krell dealer or distributor. Previously owned equipment, when re-purchased from an authorized Krell dealer or distributor, has the balance of the original warranty, based on the original date of manufacture.

The warranty for Krell products is valid only in the country to which they were originally shipped, through the authorized Krell distributor for that country, and at the factory. There may be restrictions on or changes to Krell's warranty because of regulations within a specific country. Please check with your distributor for a complete understanding of the warranty in your country.

If a unit is serviced by a distributor who did not import the unit, there may be a charge for service, even if the product is within the warranty period.

Freight to the factory is your responsibility. Return freight within the United States (U.S.A.) is included in the warranty. If you have purchased your Krell product outside the U.S.A. and wish to have it serviced at the factory, all freight and associated charges to the factory are your responsibility.

Krell will pay return freight to the U.S.A.-based freight forwarder of your choice. Freight and other charges to ship the unit from the freight forwarder to you are also your responsibility.

Krell is not responsible for any damage incurred in transit. Krell will file claims for damages as necessary for units damaged in transit to the factory. You are responsible for filing claims for shipping damages during the return shipment.

Krell does not supply replacement parts and/or products to the owner of the unit. Replacement parts and/or products will be furnished only to the distributor performing service on this unit on an exchange basis only; any parts and/or products returned to Krell for exchange become the property of Krell.

No expressed or implied warranty is made for any Krell product damaged by accident, abuse, misuse, natural or personal disaster, or unauthorized modification.

Any unauthorized voltage conversion, disassembly, component replacement, perforation of chassis, updates, or modifications performed to the unit will void the warranty.

The operating voltage of this unit is determined by the factory and can only be changed by an authorized Krell distributor or at the factory. The voltage for this product in the U.S.A. cannot be changed until six months from the original purchase date.

In the event that Krell receives a product for warranty service that has been modified in any way without Krell authorization, all warranties on that product will be void. The product will be returned to original factory layout specifications at the owner's expense before it is repaired. All repairs required after the product has been returned to original factory specifications will be charged to the customer, at current parts and labor rates.

All operational features, functions, and specifications and policies are subject to change without notification.

To register your product for warranty benefits, please complete and return the Warranty Registration Card enclosed in the shipping box within 15 days of purchase. Thank you.

Return Authorization Procedure

If you believe there is a problem with your component, please contact your dealer, distributor, or the Krell factory to discuss the problem before you return the component for repair. To expedite service, you may wish to complete and e-mail the Service Request Form in the Service Section of our website at:

<http://www.krellonline.com>

To contact the Krell Service Department

TEL **203-799-9954**
 Monday-Friday
 9:00 AM to 5:00 PM EST

FAX **203-799-9796**

E-MAIL **service@krellonline.com**

WEBSITE **<http://www.krellonline.com>**

PRODUCT NAME

MODEL NUMBER

SERIAL NUMBER

To return this product to Krell, please follow this procedure so that we may serve you better:

1. Obtain a Return Authorization Number (R/A number) and shipping address from the Krell Service Department.
2. Insure and accept all liability for loss of or damage to this product during shipment to the Krell factory and prepay all shipping charges. Please see the Warranty page in this manual, concerning liability for shipping damage and shipping charges.

This product may also be hand delivered if arrangements with the Service Department have been made in advance. Proof of purchase will be required for warranty validation at the time of hand delivery.

IMPORTANT

Use the original packaging to ensure safe transit of this product to the dealer, distributor, or factory. Krell may, at its discretion, return this product in new packaging and bill the owner for such packaging if the product received by Krell was boxed in non-standard packaging or if the original packaging was so damaged that it was unuseable. If Krell determines that new packaging is required, the owner will be notified before this product is returned.

To purchase additional packaging, please contact your authorized Krell dealer, distributor, or the Krell Service Department.

Specifications

KAV-2250

FREQUENCY RESPONSE	20 Hz to 20 kHz 0.25 Hz to 170 kHz	+0 dB, -0.09 dB +0 dB, -3 dB
SIGNAL TO NOISE RATIO "A" WEIGHTED	>112 dB	
TOTAL HARMONIC DISTORTION (THD)	1 kHz 20 kHz	< 0.03% < 0.20%
GAIN	25.7 dB	
INPUT IMPEDANCE	100 kOhms	
INPUT SENSITIVITY	2.32 Vrms	
OUTPUT VOLTAGE	Peak to Peak RMS	127 V 45 V
OUTPUT POWER EACH CHANNEL	8 Ohms 4 Ohms	250 W 500 W
BRIDGED	8 Ohms	1000 W
POWER CONSUMPTION	Standby Idle Max.	35 W 80 W 2000 W
INPUTS	2 single-ended via RCA connectors 2 balanced via XLR connectors	
OUTPUTS	2 amplifier channels via five-way binding posts	
REMOTE CONNECTORS	12 VDC Out (12 V trigger) via a 3.5 mm connector 12 VDC In (12 V trigger) via a 3.5 mm connector	
DIMENSIONS	17.3w x 5.6h x 17.1d in. 43.8w x 14.3h x 43.4d cm	
WEIGHT		
SHIPPING	74.0 lb., 33.5 kg	
UNIT ONLY	64.0 lb., 29.0 kg	

All operational features, functions, specifications, and policies are subject to change without notification.

Specifications

KAV-3250

FREQUENCY RESPONSE	20 Hz to 20 kHz 0.25 Hz to 170 kHz	+0 dB, -0.09 dB +0 dB, -3 dB
SIGNAL TO NOISE RATIO "A" WEIGHTED	>112 dB	
TOTAL HARMONIC DISTORTION (THD)	1 kHz 20 kHz	< 0.03% < 0.20%
GAIN	25.7 dB	
INPUT IMPEDANCE	100 kOhms	
INPUT SENSITIVITY	2.32 Vrms	
OUTPUT VOLTAGE	Peak to Peak RMS	127 V 45 V
OUTPUT POWER EACH CHANNEL	8 Ohms 4 Ohms	250 W 500 W
BRIDGED	8 Ohms	1000 W
POWER CONSUMPTION	Standby Idle Max.	45 W 115 W 2000 W
INPUTS	3 single-ended via RCA connectors 3 balanced via XLR connectors	
OUTPUTS	3 amplifier channels via five-way binding posts	
REMOTE CONNECTORS	12 VDC Out (12 V trigger) via a 3.5 mm connector 12 VDC In (12 V trigger) via a 3.5 mm connector	
DIMENSIONS	17.3w x 5.6h x 17.1d in. 43.8w x 14.3h x 43.4d cm	
WEIGHT		
SHIPPING	78.0 lb., 35.3 kg	
UNIT ONLY	68.0 lb., 30.8 kg	

All operational features, functions, specifications, and policies are subject to change without notification.

Krell Industries, Inc.
45 Connair Road
Orange, CT 06477-3650 USA

TEL 203-799-9954
FAX 203-891-2028
E-MAIL krell@krellonline.com
WEBSITE <http://www.krellonline.com>

KAV-2250
Stereo Power Amplifier

KAV-3250
Three-channel Power Amplifier
v 01.2
