



**Theater Amplifier
Standard
Multichannel Amplifier**

Instructions for Use

Owner's Reference

**Theater Amplifier
Standard
Multichannel Amplifier
Instructions for Use**

v 02.0

**Krell Industries, Inc.
45 Connair Road
Orange, CT 06477-3650 USA
TEL 203-799-9954
FAX 203-891-2028
E-MAIL krell@krellonline.com
WEBSITE <http://www.krellonline.com>**



This product complies with the EMC directive (89/336/EEC) and the low-voltage directive (73/23/EEC).

WARNINGS

The amplifier must be placed on a firm, level surface where it is not exposed to dripping or splashing.

The ventilation grids on the top, bottom, and sides of the amplifier must be unobstructed at all times during operation. Do not place flammable material above or beneath the amplifier.

Contact your authorized Krell dealer, distributor, or Krell before using any devices designed to alter or stabilize the AC power for the Theater Amplifier Standard.

Before connecting the Theater Amplifier Standard, make sure the amplifier is turned off and any output device (such as a preamplifier) is in mute or stand-by mode. Make sure all cable terminations are of the highest quality and free from frayed ends, short circuits, or cold solder joints.

Use only one set of inputs to the amplifier at a time.

Make sure that only one switch on an input switch bank is in the up (on) position at one time.

Do not connect the multichannel (DB-25) input and the single-ended or balanced inputs at the same time.

THERE ARE NO USER SERVICEABLE PARTS INSIDE ANY KRELL PRODUCT.

Please contact your authorized Krell dealer, distributor, or Krell if you have any questions not addressed in this reference manual.

This product is manufactured in the United States of America. Krell® is a registered trademark of Krell Industries, Inc., and is restricted for use by Krell Industries, Inc., its subsidiaries, and authorized agents. Multi Amp Throughput™ and Krell Current Mode™ are trademarks of Krell Industries, Inc. All other trademarks and tradenames are registered to their respective companies.

Contents	Page
INTRODUCTION	1
DEFINITION OF TERMS	2
UNPACKING	4
PLACEMENT	5
AC Power Guidelines	5
FRONT PANEL DESCRIPTION: THEATER AMPLIFIER STANDARD	7
BACK PANEL DESCRIPTION: THEATER AMPLIFIER STANDARD	9
CONNECTING THE THEATER AMPLIFIER STANDARD TO YOUR SYSTEM	11
Input and Output Connections	11
AMPLIFIER OPERATION	13
On/Off and Operation	13
Using a Dedicated Wall Switch	13
TROUBLESHOOTING SYSTEM NOISE	14
RECONFIGURATION OPTIONS FOR THE THEATER AMPLIFIER STANDARD	15
To Safely Access the Input Switch Banks	15
Amplifier Factory Default Settings	18
Reconfiguring the Theater Amplifier Standard for MAT Operation	18
Reconfiguring the Theater Amplifier Standard for Bridged Operation	22
Reconfiguring the Theater Amplifier Standard for Combined MAT and Bridged Operation	24
Example of a Connection Scenario: Multi-power Mode	25
QUESTIONS AND ANSWERS	27
WARRANTY	28
RETURN AUTHORIZATION PROCEDURE	29
SPECIFICATIONS	30

Illustrations

Page

FIGURE 1	The Theater Amplifier Standard Front Panel	6
FIGURE 2	The Theater Amplifier Standard Back Panel	8
FIGURE 3	The Theater Amplifier Standard Input Circuit Board Factory Default Settings	16
FIGURE 4	Reconfiguring the Theater Amplifier Standard for MAT Operation	17
FIGURE 5	Reconfiguring the Theater Amplifier Standard for Bridged Operation	21
FIGURE 6	Reconfiguring the Theater Amplifier Standard for Combined MAT and Bridged Operation	23

Introduction

Thank you for your purchase of the Krell Theater Amplifier Standard Multichannel Amplifier.

The Theater Amplifier Standard provides substantial five-channel output power that delivers realistic music reproduction at an exceptional value. The amplifier channels can be customized quickly through a series of switches. Optional system configurations include bridged operation and a multi-power mode using the Multi Amp Throughput (MAT) feature. The Theater Amplifier Standard has balanced and single-ended inputs for compatibility with other components. The multichannel (DB-25) input also allows you to integrate the amplifier easily and seamlessly into home theater systems. The amplifier can be operated using the 12 VDC power on/off (12 V trigger) signals from other components. The Theater Amplifier Standard is versatile, fitting a variety of installations including rack-mounted and inside cabinetry.

This reference manual contains important information on placement, installation, and operation of the Theater Amplifier Standard. Please read this information carefully. A thorough understanding of these details helps ensure satisfactory operation and long life for your Theater Amplifier Standard and related system components.

Definition of Terms

Following are the definitions of key terms used in your owner's reference manual.

CONFIGURATIONS

Bridging

A method of linking two amplifier channels by distributing the speaker load between the positive binding posts. Bridging the channels quadruples the power rating at 8 Ohms. Bridged configurations should not be used with loads under 4 Ohms.

Krell Multi Amp Throughput (MAT)

An internal configuration option that sends the same music signal to all amplifier channels using one balanced or single-ended connection. MAT reduces installation complexity and cabling requirements in systems containing multiple amplifiers. MAT also allows a variety of connection scenarios, including powering loudspeakers that have two sets of binding posts and independently powering multiple pairs of stereo loudspeakers to extend the listening environment throughout your home.

INPUT AND OUTPUT CONNECTIONS

Balanced

A symmetrical input or output circuit that has equal impedance from both input terminals to a common ground reference point. The industry standard for professional and sound recording installations, balanced connections have 6 dB more gain than single-ended connections and allow the use of long interconnect cables. Balanced connections are less susceptible than single-ended connections to induced noise from the system or the environment.

Multichannel (DB-25)

A balanced input or output circuit that allows for the simultaneous connection of all audio outputs plus one 5 VDC (5 Volt trigger) via a single cable. DB-25 inputs and outputs are becoming popular for connecting an audio/video surround sound processor and power amplifiers, simplifying the integration of the two components into your system.

Single-ended

A two-wire input or output circuit. Use care when using single-ended connections as the ground connection is made last and broken first. Turn the system off prior to making or breaking single-ended connections. Single-ended connections are not recommended for connections requiring long cable runs.

Definition of Terms, continued

OPERATION

Off

When the back panel power switch is in the down (off) position and the red stand-by LED turns off, the component is off.

Stand-by Mode

When the AC power cord is plugged into the wall and the back panel power switch is in the up (on) position, the red stand-by LED illuminates, indicating that the component is in the stand-by mode. This low power consumption status keeps the audio and regulator circuits at idle. Krell recommends leaving the component in the stand-by mode when it is not playing music.

Operational Mode

From the stand-by mode, when the power button on the front panel is pressed and the blue power indicator illuminates, the component is in the operational mode and ready to play music.

TECHNOLOGY

Krell Current Mode

A proprietary Krell circuit topology in which the audio gain stages of a component operate in the current rather than the voltage domain. This unique technology provides the component with exceptional speed and a wide bandwidth.

Unpacking

Open the shipping box, which contains:

- 1 amplifier unit (packed in foam end-caps)
- 1 AC power cord
- 5 AGC-12 (12-amp) speaker fuses
- 1 12 VDC output (12 V trigger) cable
- 1 T-15 Torx wrench
- 1 packet containing the owner's reference manual and the warranty registration card.

IMPORTANT

Two people are needed to remove the amplifier from the shipping box.

1. One person grasps the underside of the foam end-caps at one end of the amplifier; at the same time, the second person grasps the underside of the foam end-caps at the other end of the amplifier.
2. Slowly lift the amplifier straight out of the shipping box.
3. Place the amplifier in a safe location and remove the protective plastic wrapping.

Notes

If any of these items are not included in the shipping box, please contact your authorized Krell dealer, distributor, or Krell for assistance.

*Save all packing materials. If you ship your amplifier in the future, repack the unit in its original packaging to prevent transit damage. See **Return Authorization Procedure**, on page 29, for more information.*

Placement

Before you integrate the Theater Amplifier Standard into your system, review the following guidelines to choose the location for the component. This will facilitate a clean, trouble-free installation.

The Theater Amplifier Standard requires at least two inches (5 cm) of clearance on each side and at least two inches (5 cm) of clearance above and below the component to provide adequate ventilation.

The Theater Amplifier Standard does not require any type of special rack or cabinet for installation. For the dimensions of your amplifier see ***Specifications***, on page 30.

Place the amplifier as close to the loudspeakers as possible and keep the speaker cable length to a minimum. Speaker cable adds impedance to the load the amplifier must drive, regardless of the cable's gauge. Krell amplifiers drive the lowest impedances with ease, but long speaker cables reduce the maximum power that is delivered to the loudspeakers.

AC POWER GUIDELINES

Krell recommends operating the Theater Amplifier Standard from a dedicated 20-amp AC power line. The Theater Amplifier Standard should be used only with the AC power cord supplied. Please contact your Krell dealer, distributor, or Krell before using any devices designed to alter or stabilize the AC power for the Theater Amplifier Standard.

Figure 1 The Theater Amplifier Standard Front Panel

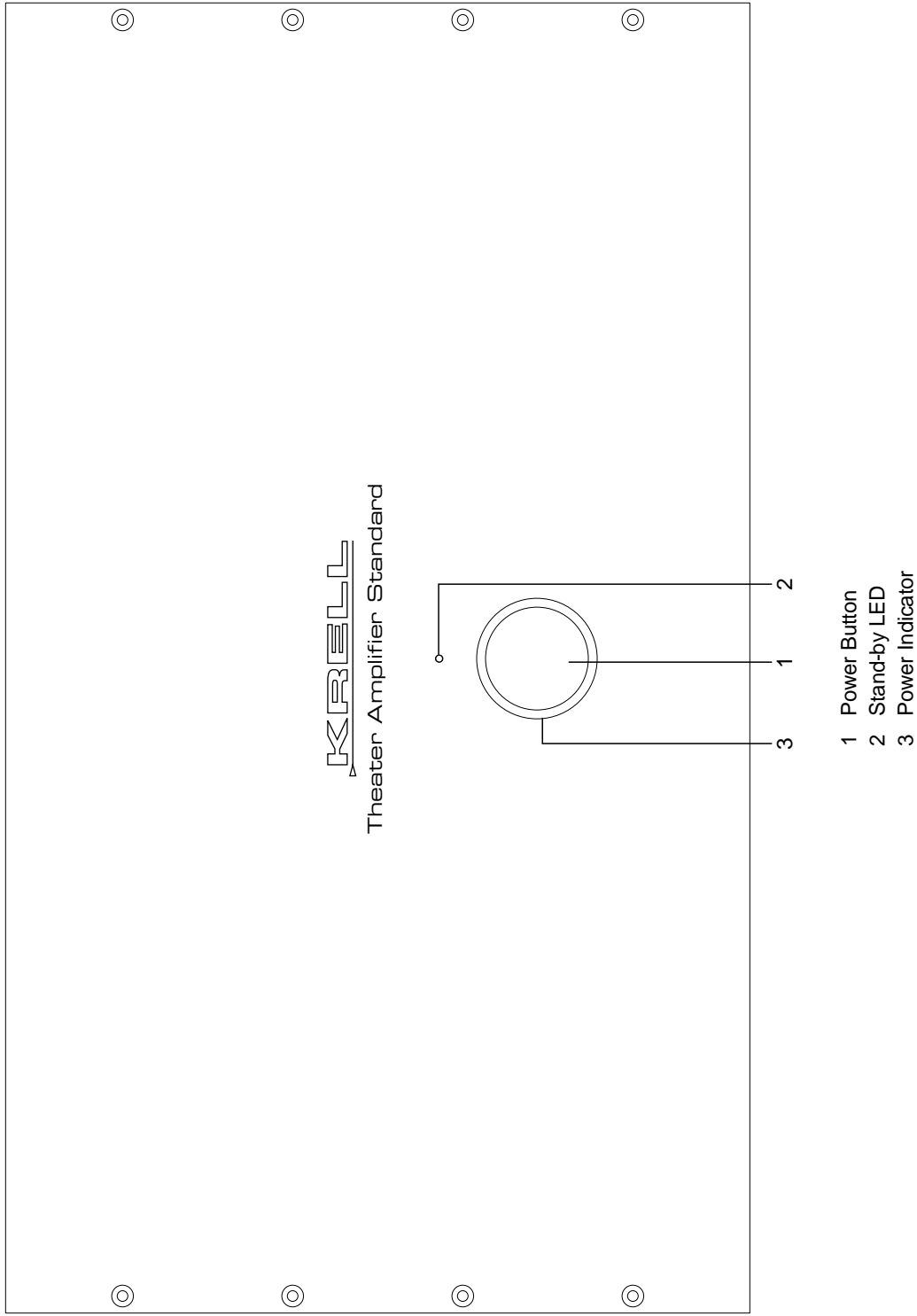

Front Panel Description: Theater Amplifier Standard

See Figure 1 on page 6

The Theater Amplifier Standard front panel provides power on and indicates operating status.

1 Power Button

Use this button to switch the Theater Amplifier Standard power between the stand-by and the operational modes and also to switch the 12 VDC output (12 V trigger) on and off.

2 Stand-by LED

The red stand-by LED illuminates when the AC power cord is plugged into the wall and the back panel power switch is in the up (on) position.

3 Power Indicator

The blue power indicator illuminates when the amplifier is in the operational mode.

Figure 2 The Theater Amplifier Standard Back Panel

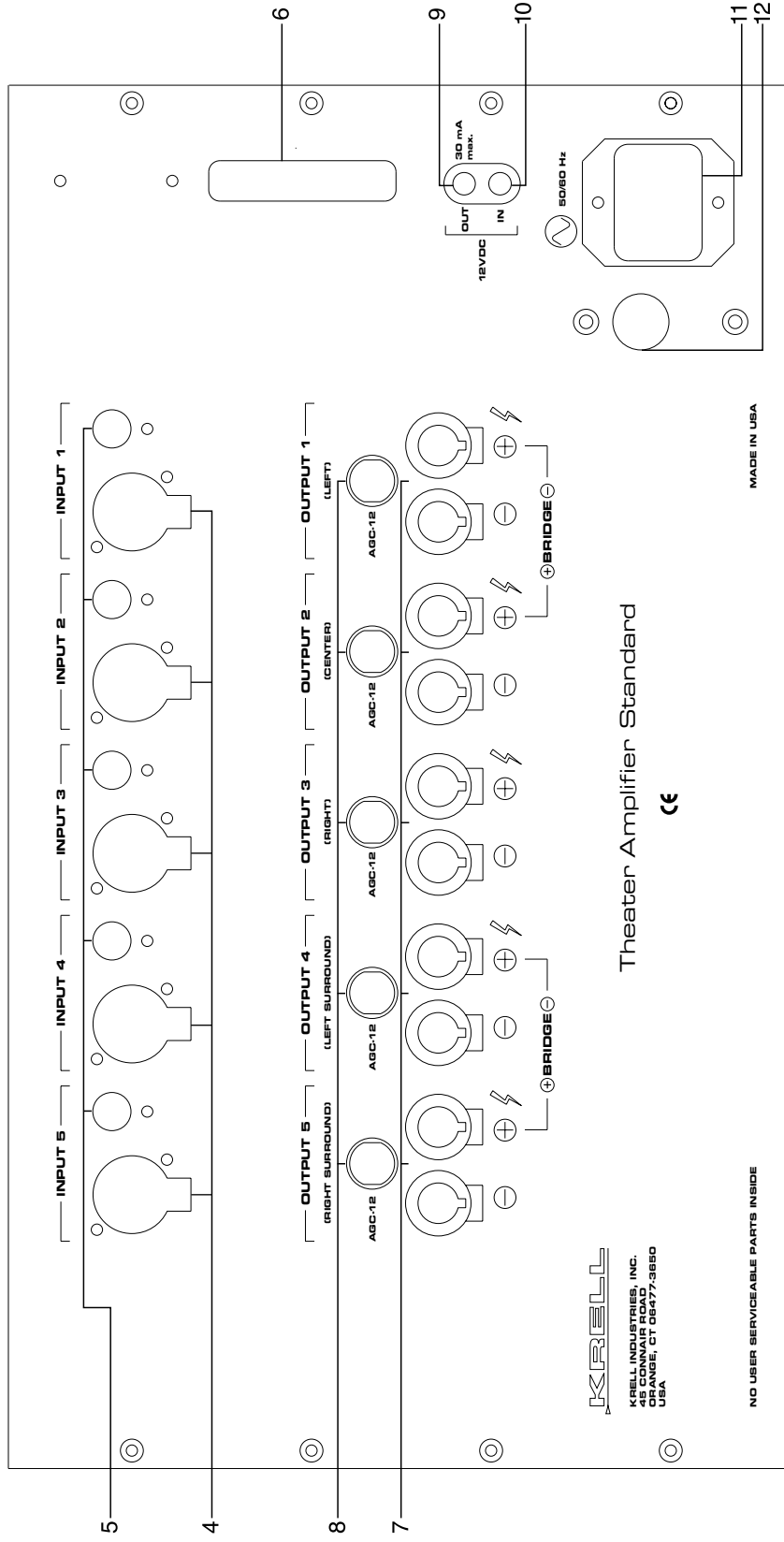

- | | | |
|----------------------------|----------------------------------|----------------------------|
| Balanced Inputs | Amplifier Channel Outputs | Remote Connections |
| 4 Inputs 1-5 | 7 Outputs 1-5 | 9 12 VDC Remote Power Out |
| Single-ended Inputs | Fuses | 10 12 VDC Remote Power In |
| 5 Inputs 1-5 | 8 AGC-12 Fuses | Power |
| Multichannel Input | | 11 AC Power Cord |
| 6 Multichannel Input | | 12 Back Panel Power Switch |

Back Panel Description: Theater Amplifier Standard

See Figure 2 on page 8

The Theater Amplifier Standard back panel provides connections for all inputs and outputs, remote connection input and output links, and AC power supply. See ***Reconfiguration Options for the Theater Amplifier Standard***, on pages 15-26, for information on optional system configurations and amplifier channel output connections.

Balanced Inputs

4 Inputs 1-5

The Theater Amplifier Standard has five channel inputs for output devices with balanced XLR connectors.

Single-ended Inputs

5 Inputs 1-5

The Theater Amplifier Standard has five channel inputs for output devices with single-ended RCA connectors.

Multichannel Input

6 Multichannel Input

The Theater Amplifier Standard has one DB-25 input, for connecting to the DB-25 output of a preamp/processor. The DB-25 input incorporates all five channels plus a 5 VDC (5 Volt trigger), allowing you to send all audio signals and turn the amplifier on and off via a single cable.

IMPORTANT

Do not connect the multichannel (DB-25) input and the single-ended or balanced inputs at the same time.

Use only one set of inputs to the amplifier at a time.

Amplifier Channel Outputs

7 Outputs 1-5

The Theater Amplifier Standard has five amplifier channel outputs. The loudspeaker binding post terminals accept spade lugs, bare wire, or pins. Use the red terminal for the positive connection and the black terminal for the negative connection.

IMPORTANT

Tighten loudspeaker binding posts by hand only.

Back Panel Description, continued

Fuses

8 AGC-12 Fuses

The AGC 12 Amp loudspeaker fuses protect the Theater Amplifier Standard against short circuits at the amplifier outputs.

Back Panel Remote Connections

9 12 VDC Remote Power Out

The Theater Amplifier Standard is equipped with an output that sends 12 VDC power on/off (12 V trigger) signals to other Krell components and other devices that incorporate a 12 V trigger.

Notes

When the component is in the operational mode, the 12 VDC Out provides 12 V of DC output. When the component is in the stand-by mode or off, the DC output is 0 V.

12 VDC Out (12 V trigger) current is limited to 30 mA.

10 12 VDC Remote Power In

The Theater Amplifier Standard is equipped with an input that receives 12 VDC power on/off (12 V trigger) signals from other Krell components and other devices that incorporate a 12 V trigger. This allows you to turn the Theater Amplifier Standard on and off using a Krell or other component in a custom installation.

Note

Consult the owner's manual of each component used in a custom installation to take full advantage of the Theater Amplifier Standard remote capability.

Power

11 IEC Connector

The Theater Amplifier Standard is equipped with a standard IEC power connector for use with the AC power cord.

12 Back Panel Power Switch

Use this switch to turn the Theater Amplifier Standard from off to the stand-by mode.

Connecting the Theater Amplifier Standard to Your System

INPUT AND OUTPUT CONNECTIONS

The Theater Amplifier Standard is equipped with balanced and single-ended inputs and a multi-channel DB-25 connector.

Krell recommends using balanced interconnect cables. Balanced interconnect cables not only can minimize sonic loss but are also immune to induced noise, especially with installations using long cables. Balanced connections have 6 dB more gain than single-ended connections. When level matching is critical, please keep this gain value in mind.

The Theater Amplifier Standard is shipped with shorting pins in the XLR inputs. These pins should remain in the XLR inputs if the amplifier is operating in the single-ended mode. When the shorting pin is inserted, pins 1 (lower left) and 3 (top) are shorted together. Remove the shorting pins to connect the amplifier for balanced or multi-channel DB-25 operation.

The XLR pin configuration is described below:

- Pin 1 Shield (ground)
- Pin 2 Non-inverting (hot) (0°)
- Pin 3 Inverting (cold) (180°)

Follow these steps to connect the Theater Amplifier Standard to your system.

1. Make sure all power sources and components are off before connecting inputs and outputs.
2. Neatly organize the wiring between the amplifier and all system components. Separate AC wires from audio cables to prevent hum or other unwanted noise from being introduced into the system.
3. Connect the interconnect cables from your source components to the amplifier inputs using the balanced (4) or single-ended (5) inputs located on the back panel. The balanced inputs use three-pin XLR connectors; the single-ended inputs use RCA connectors.

or

Connecting the Theater Amplifier Standard, continued

Use the multichannel (DB-25) connector to simplify the integration of the Theater Amplifier Standard into your system:

Connect the DB-25 output on your preamp/processor to the DB-25 multichannel input (6) on the back panel of the Theater Amplifier Standard. The DB-25 cable simultaneously transmits audio outputs and Trigger 1 signals from the DB-25 output of the Krell Home Theater Standard Surround Preamp/processor to all inputs and to a 5 VDC (5 Volt trigger) on the Theater Amplifier Standard via the DB-25 input.

Note

If you are connecting the Home Theater Standard and the Theater Amplifier Standard via a DB-25 connector, you need to configure Trigger 1 on the Home Theater Standard before operating the Theater Amplifier Standard.

IMPORTANT

Do not connect the multichannel (DB-25) input and the single-ended or balanced inputs at the same time.

Use only one set of inputs to the amplifier at a time.

Remove the shorting pins in the XLR inputs when using the DB-25 multichannel input.

4. Connect the loudspeaker cables to the Theater Amplifier Standard channel output binding posts (7) located on the back panel.

The binding post terminals accept spade lugs, bare wire, or pins. Use the red terminal for the positive connection and the black terminal for the negative connection.

IMPORTANT

Tighten loudspeaker binding posts by hand only.

5. Insert the AC power cord into the IEC connector (11) on the Theater Amplifier Standard. Insert the other end of the AC power cord into the AC wall outlet.

The amplifier is now ready for operation. See **Amplifier Operation**, on page 13. You can also reconfigure the amplifier for Multi Amp Throughput or Bridged Operation. See **Reconfiguration Options for the Theater Amplifier Standard**, on page 15.

Amplifier Operation

ON/OFF AND OPERATION

When powering up your system, turn amplifiers **on last**. When powering down your system, turn amplifiers **off first**. The procedures for amplifier operation follow.

1. Plug the end of the AC power cord (11) into the AC wall outlet.
2. Push the back panel power switch (12) up (on). You will hear two clicks, then the red stand-by LED (2) illuminates.

There is a brief delay before the component can be put in the operational mode. Please wait approximately 10 seconds.

3. Press the power button (1) on the front panel. The blue power indicator (3) illuminates and you hear a click. The amplifier is in the operational mode.

Krell recommends leaving the Theater Amplifier Standard in the stand-by mode unless you will not be playing music for a long time.

IMPORTANT

Always turn the amplifier off before changing input connections, and mute or fully attenuate the preamplifier level when switching sources.

The Theater Amplifier Standard has tremendous reserves of power and safely drives loudspeakers to extremely high sound pressure levels. However, use care when setting high playback levels and lower the volume level at any sign of loudspeaker distress.

USING A DEDICATED WALL SWITCH

The Theater Amplifier Standard can also be powered on from an AC wall receptacle with a dedicated switch, rather than from the front panel power button. Please contact your authorized Krell dealer, distributor, or Krell for more information before you connect the Theater Amplifier Standard to a dedicated AC wall outlet with a switch.

Troubleshooting System Noise

When you mix and match high-performance audio components, each with its own ground potential, a low frequency hum may occur in one or all loudspeakers. If this happens when you place the Theater Amplifier Standard into your system, follow these simple troubleshooting steps:

1. Check that all input and output connections are of sound construction.
2. With the amplifier off, remove all the interconnect cables, then turn the amplifier on. If the hum disappears, turn the amplifier off and reinsert one of the interconnect cables. Turn the amplifier back on.
3. If the hum reappears with the interconnect cable reinserted, the cable may need to be replaced. Turn the amplifier off and connect a different interconnect cable to the same location. Turn the amplifier back on.
4. If the hum disappears with the interconnect cable reinserted, that cable most likely is sound.
5. Turn the amplifier off, disconnect the interconnect cable, and re-connect one of the other interconnect cables.
6. Repeat steps 3 through 5 until you have checked each interconnect cable.
7. If all the interconnect cables appear to be sound, and you still have hum, you may be experiencing a ground loop. Please contact your authorized Krell dealer, distributor, or Krell for suggestions on how to eliminate it.

Reconfiguration Options for the Theater Amplifier Standard

The Theater Amplifier Standard offers a number of options for configuring your amplifier output and is unique in that it allows you to bridge and use Multi Amp Throughput at the same time.

Multi Amp Throughput (MAT) is an internal connection option for the Theater Amplifier Standard that lets you send the same music signal to all amplifier channels using one balanced or single-ended connection. MAT reduces installation complexity and cabling requirements in systems containing multiple amplifiers.

Bridging allows you to reconfigure four of the Theater Amplifier Standard channels to operate as two combined amplifier channels. The bridged amplifier channels each deliver 800 Watts into an 8 Ohm load. The remaining unbridged amplifier channel can be connected to a separate loudspeaker.

IMPORTANT

*Removing the cover to reconfigure for MAT or for bridged operation is the **ONLY** instance you are authorized to remove the cover of **ANY** Krell component without voiding your Warranty. For more information on product limitations and restrictions, see **Warranty**, on page 28.*

TO SAFELY ACCESS THE INPUT SWITCH BANKS

Read the following important instructions to safely remove the amplifier cover to reconfigure the Theater Amplifier Standard.

Tool needed: T-15 Torx wrench

1. Unplug the AC power cord from AC power.
2. Krell suggests removing jewelry before reconfiguring your amplifier. Rings, necklaces, bracelets, and other metal jewelry can conduct an electrical charge.
3. Using the T-15 Torx wrench, remove the 12 screws that secure the amplifier cover.
4. Carefully remove the cover.
5. Locate the green input circuit board, white input switches, and red input switch banks, at the rear of the amplifier.
6. Reconfigure your amplifier, using the scenarios described below.

Figure 3 The Theater Amplifier Standard Input Circuit Board Factory Default Settings

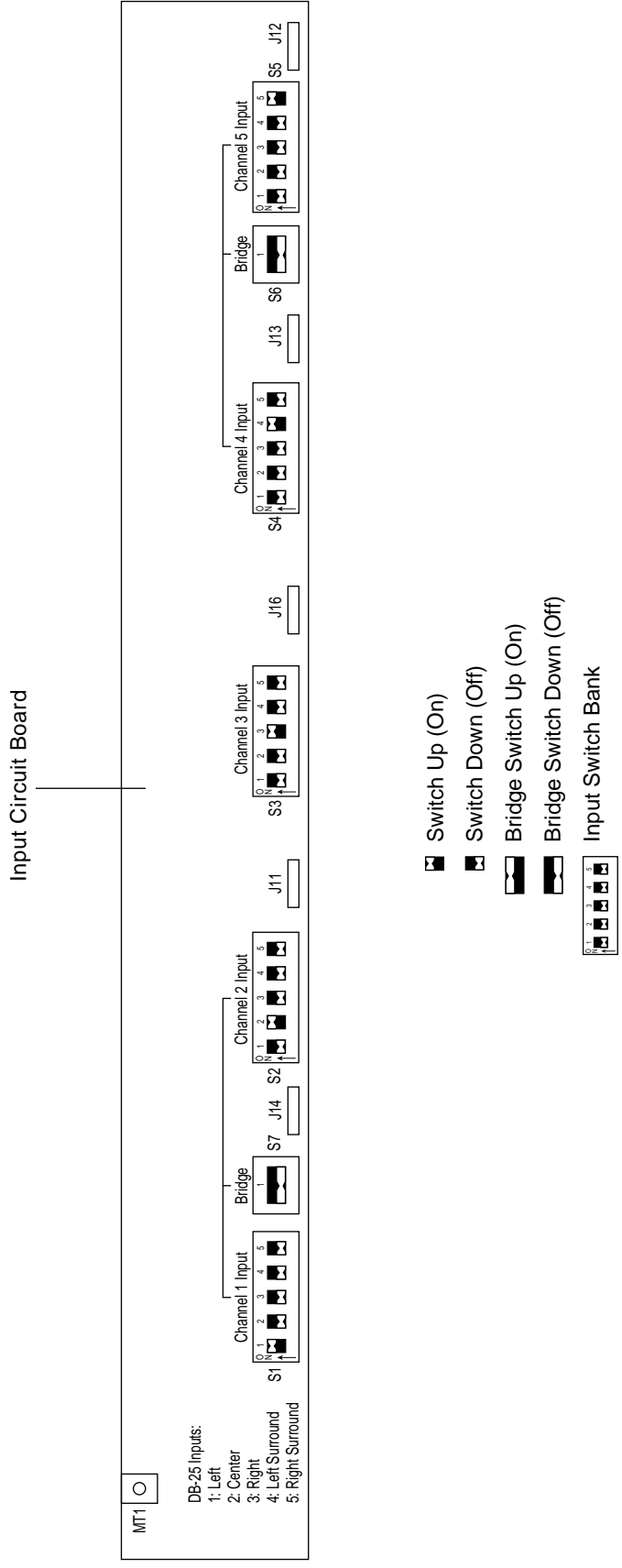
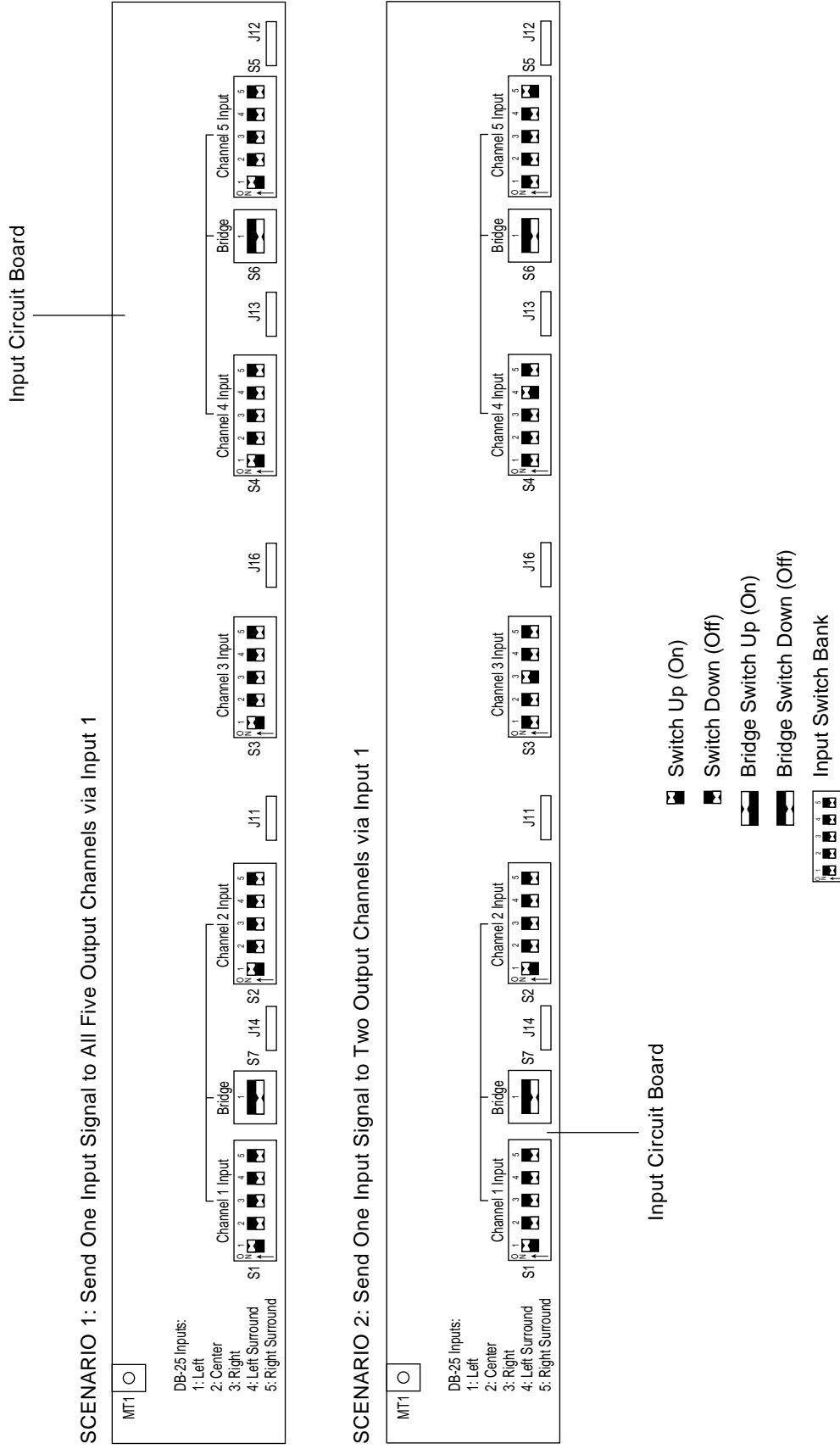

Figure 4 Reconfiguring the Theater Amplifier Standard for MAT Operation



Reconfiguration Options, continued

Accessing the Input Switch Banks, continued

7. After the component is configured, replace the cover and, using the T-15 Torx wrench, secure all 12 cover screws.

IMPORTANT

Operating the amplifier without the cover properly replaced and secured may void your Warranty.

AMPLIFIER FACTORY DEFAULT SETTINGS

See Figure 3 on page 16

The amplifier is shipped with input switch banks set to the following factory defaults:

1. For input switch bank 1: switch 1 up (on), other switches down (off).
2. For input switch bank 2: switch 2 up (on), other switches down (off).
3. For input switch bank 3: switch 3 up (on), other switches down (off).
4. For input switch bank 4: switch 4 up (on), other switches down (off).
5. For input switch bank 5: switch 5 up (on), other switches down (off).

RECONFIGURING THE THEATER AMPLIFIER STANDARD FOR MAT OPERATION

Send One Input Signal to All Five Output Channels via Input 1 (Scenario 1)

See Figure 4 on page 17

1. Push switch 1 up (on) for all input switch banks.
2. Push switches 2-5 down (off) for all input switch banks.

Although Figure 4 illustrates sending the signal from input 1 to all five channels, you can send the signal from any of the inputs, depending on your preferences.

To Send One Input Signal to all Five Output Channels via Input 2

Not illustrated

1. Push switch 2 up (on) for all input switch banks.
2. Push switches 1, 3, 4, and 5 down (off) for all input switch banks.

Reconfiguration Options, continued

To Send One Input Signal to all Five Output Channels via Input 3

Not illustrated

1. Push switch 3 up (on) for all input switch banks.
2. Push switches 1, 2, 4, and 5 down (off) for all input switch banks.

To Send One Input Signal to all Five Output Channels via Input 4

Not illustrated

1. Push switch 4 up (on) for all input switch banks.
2. Push switches 1, 2, 3, and 5 down (off) for all input switch banks.

To Send One Input Signal to all Five Output Channels via Input 5

Not illustrated

1. Push switch 5 up (on) for all input switch banks.
2. Push switches 1, 2, 3, and 4 down (off) for all input switch banks.

Connecting the Theater Amplifier Standard Reconfigured for MAT (Scenario 1)

IMPORTANT

Do not use the multi-channel (DB-25) input if you have reconfigured the Theater Amplifier Standard for MAT operation.

1. Connect the cable from your source device to the balanced or single-ended input you have selected to receive the signal. (For example, the switch settings shown in Figure 4 are for using input 1.)
2. Connect each amplifier channel output to a separate loudspeaker.

Send One Input Signal to Two Output Channels via Input 1 (Scenario 2)

See Figure 4 on page 17

1. For input switch bank 1, push switch 1 up (on).
2. For input switch bank 2, push switch 1 up (on).

Reconfiguration Options, continued

3. For input switch banks 1 and 2, push switches 2-5 down (off).
4. For input switch bank 3, push switch 3 up (on) and switches 1, 2, 4, and 5 down (off).
5. For input switch bank 4, push switch 4 up (on) and switches 1, 2, 3, and 5 down (off).
6. For input switch bank 5, push switch 5 up (on) and switches 1, 2, 3, and 4 down (off).

Send One Input Signal to Two Output Channels via Input 3

Not illustrated

1. For input switch bank 3, push switch 3 up (on).
2. For input switch bank 4, push switch 3 up (on).
3. For input switch banks 3 and 4, push switches 1, 2, 4, and 5 down (off).
4. For input switch bank 1, push switch 1 up (on) and switches 2, 3, 4, and 5 down (off).
5. For input switch bank 2, push switch 2 up (on) and switches 1, 3, 4, and 5 down (off).
6. For input switch bank 5, push switch 5 up (on) and switches 1, 2, 3, and 4 down (off).

IMPORTANT

Make sure all bridging switches are down (off) unless you are bridging amplifier channels.

Connecting the Theater Amplifier Standard Reconfigured for MAT (Scenario 2)

IMPORTANT

Do not use the multichannel (DB-25) input if you have reconfigured the Theater Amplifier Standard for MAT operation.

1. Connect the cable from your source device to the balanced or single-ended input you have selected to receive the signal.
2. Connect the selected amplifier channel outputs to separate loudspeakers.

Figure 5 Reconfiguring the Theater Amplifier Standard for Bridged Operation

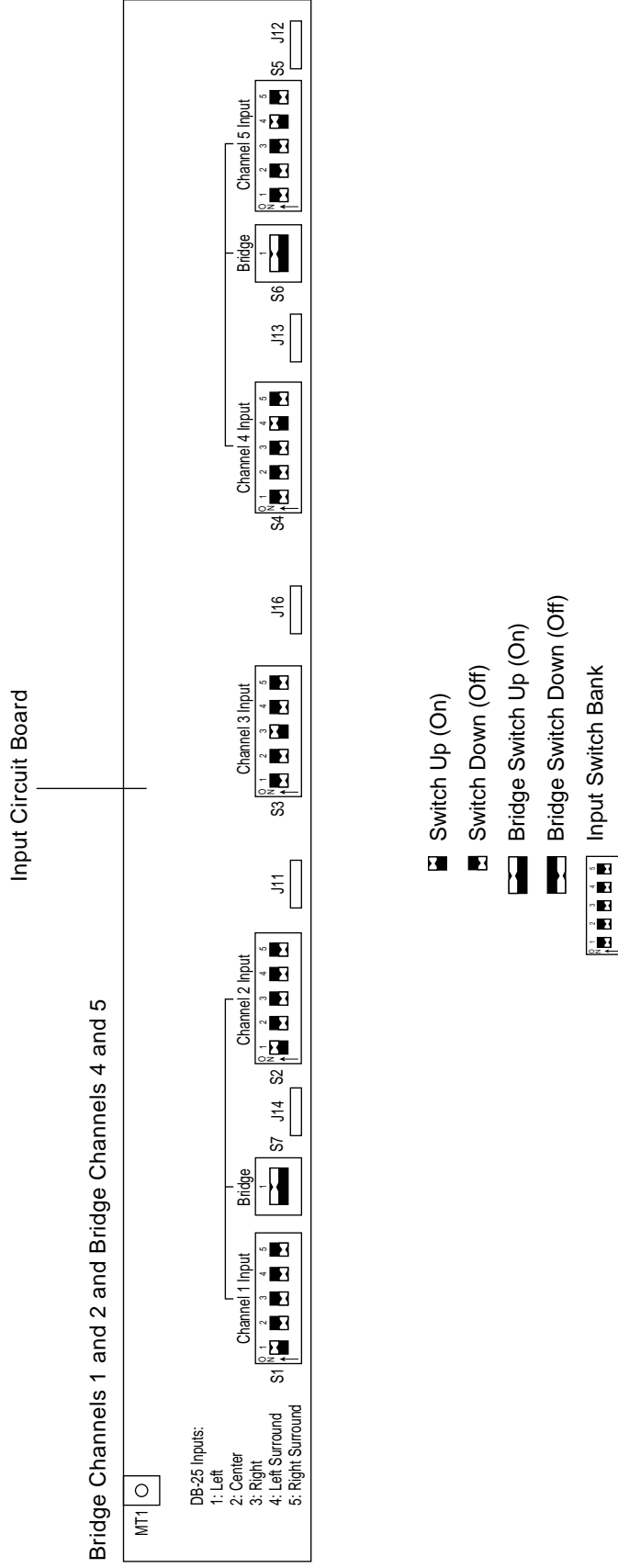

Reconfiguration Options, continued

RECONFIGURING THE THEATER AMPLIFIER STANDARD FOR BRIDGED OPERATION

Bridge Channels 1 and 2 and Bridge Channels 4 and 5

See Figure 5 on page 21

Note

Channel 3 cannot be bridged.

To bridge channels 1 and 2:

1. For input switch bank 1, push switch 1 up (on).
2. For input switch bank 2, push switch 1 up (on).
3. Push bridge switch up (on) between input switch banks 1 and 2.

Note

Input 1 is selected in the above example.

To bridge channels 4 and 5:

1. For input switch bank 4, push switch 4 up (on).
2. For input switch bank 5, push switch 4 up (on).
3. Push bridge switch up (on) between input switch banks 4 and 5.

Note

Input 4 is selected in the above example.

Connecting the Theater Amplifier Standard Reconfigured for Bridged Operation

1. Connect the cable from your source device to the balanced or single-ended input you have selected to receive the signal.
2. Connect the positive loudspeaker lead to the red binding post on the corresponding amplifier channel marked "BRIDGE +." Connect the negative loudspeaker lead to the red binding post on the amplifier channel marked "BRIDGE -."

IMPORTANT

Tighten loudspeaker binding posts by hand only.

Note

The unbridged channel may be connected to a separate loudspeaker for normal operation.

Figure 6 Reconfiguring the Theater Amplifier Standard for Combined MAT and Bridged Operation

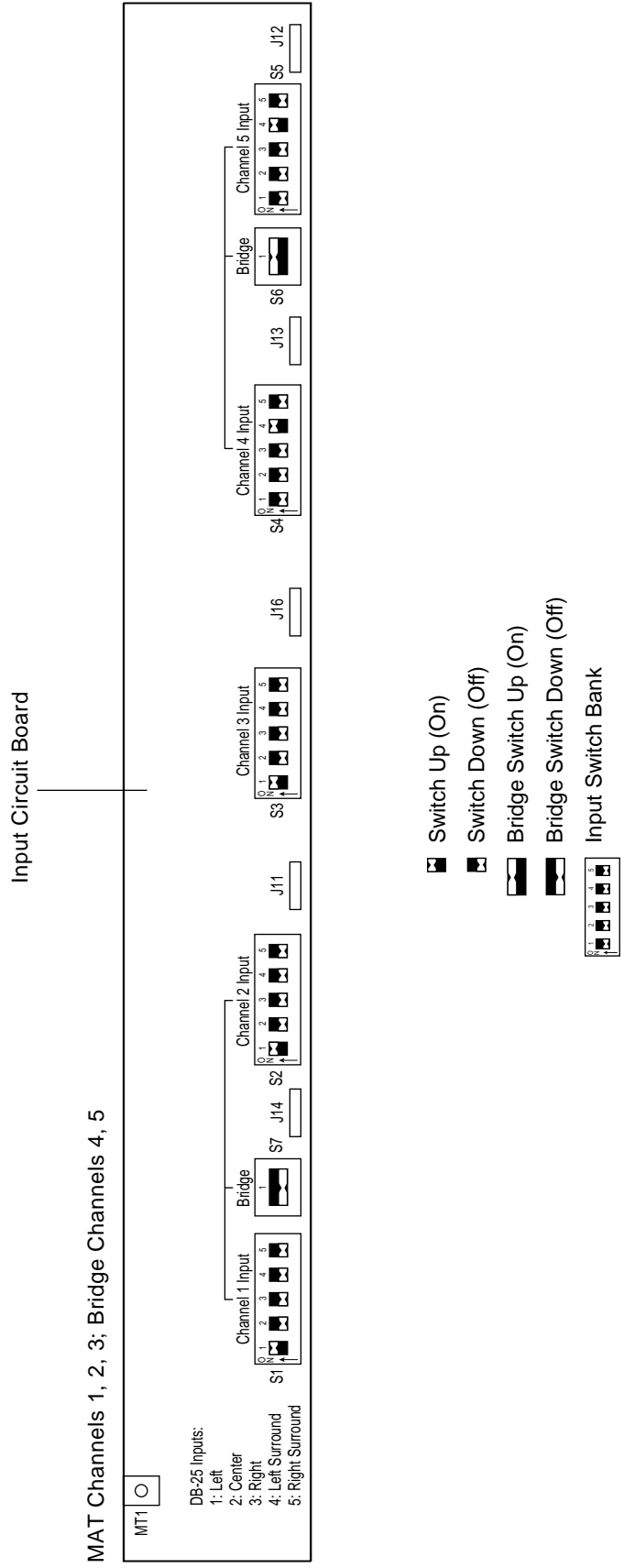

Reconfiguration Options, continued

RECONFIGURING THE THEATER AMPLIFIER STANDARD FOR COMBINED MAT AND BRIDGED OPERATION

MAT Channels 1, 2, 3 and Bridge Channels 4 and 5

See Figure 6 on page 23

This feature allows you to use MAT and bridging features at the same time. Channels 1, 2, and 3 are connected via MAT, while channels 4 and 5 are bridged.

Reconfiguring Channels 1, 2, and 3 for MAT

1. For input switch banks 1, 2, and 3, push switch 1 up (on).
2. For input switch banks 1, 2, and 3, push switches 2-5 down (off).

Connecting the Channels Configured for MAT

1. Connect the cable from your source device to the balanced or single-ended input you have selected to receive the signal. (Input 1 is selected in this example.)
2. Connect each selected amplifier channel output to a separate loudspeaker, using the positive and negative terminals on the loudspeaker binding posts.

IMPORTANT

Tighten loudspeaker binding posts by hand only.

Bridge Channels 4 and 5

1. For input switch bank 4, push switch 4 up (on).
2. For input switch bank 5, push switch 4 up (on).
3. Push bridge switch up (on) between switch banks 4 and 5.

Connecting the Bridged Channels

1. Connect the cable from your source device to the balanced or single-ended input you have selected to receive the signal. (Input 4 is selected in this example.)
2. Connect the positive loudspeaker lead to the red binding post on the corresponding amplifier channel marked "BRIDGE +." Connect the negative loudspeaker lead to the red binding post on the amplifier channel marked "BRIDGE -."

IMPORTANT

Tighten loudspeaker binding posts by hand only.

Reconfiguration Options, continued

EXAMPLE OF A CONNECTION SCENARIO: MULTI-POWER MODE

Multi-power mode is a possible connection scenario using the Theater Amplifier Standard Multi Amp Throughput (MAT) feature. With multi-power mode, you can use the Theater Amplifier Standard reconfigured for MAT to independently power multiple pairs of stereo loudspeakers, to extend the listening environment throughout your home. When the Theater Amplifier Standard is reconfigured for MAT, each channel powers an individual loudspeaker, with one Theater Amplifier Standard dedicated to driving outputs to the left loudspeakers and one Theater Amplifier Standard driving outputs to the right loudspeakers.

The diagram below illustrates this connection scenario:

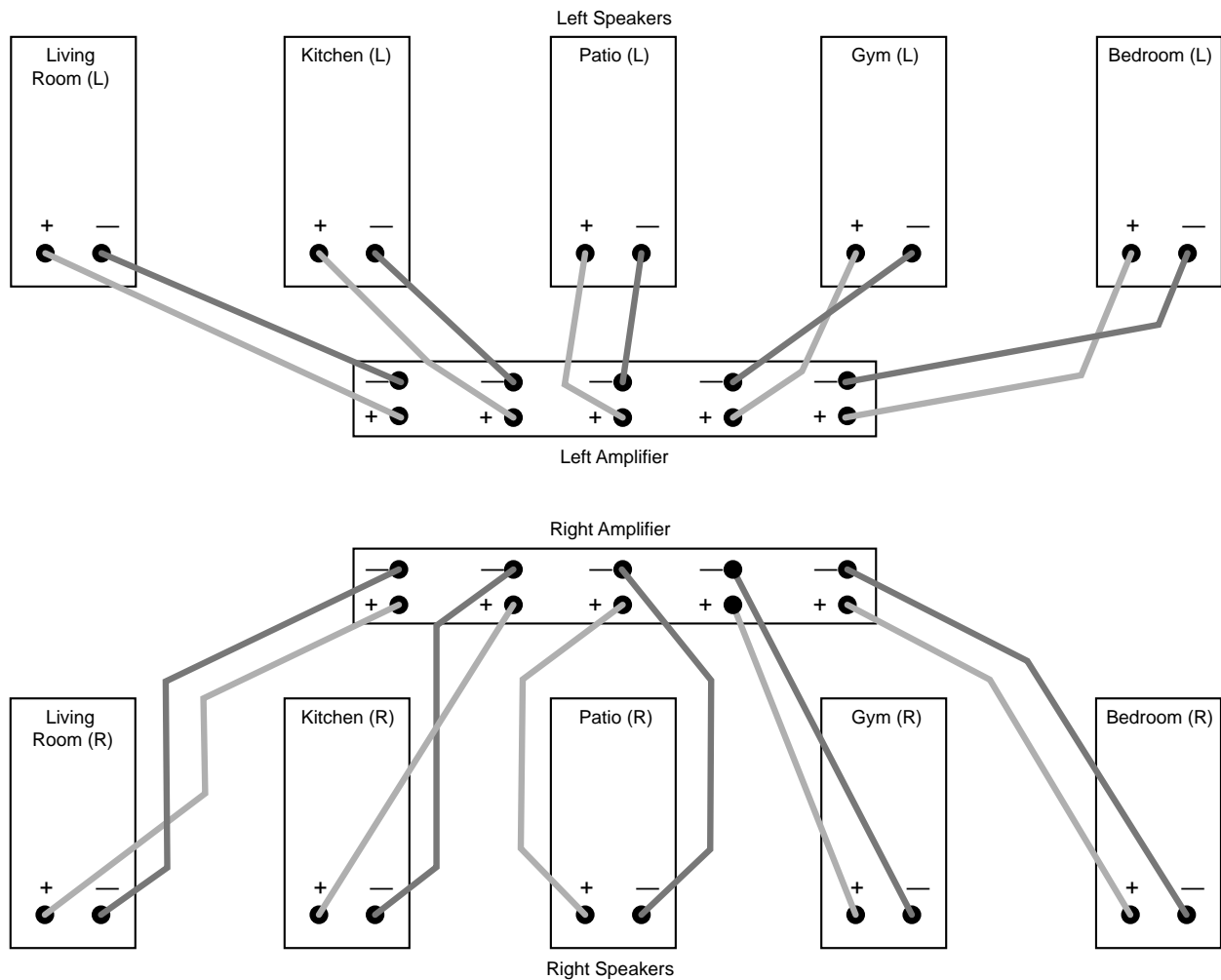

Reconfiguration Options, continued

Another option is to use one amplifier to drive speakers in different rooms, using two channels to drive the left speakers and two channels to drive the right speakers. The diagram below illustrates this connection scenario:

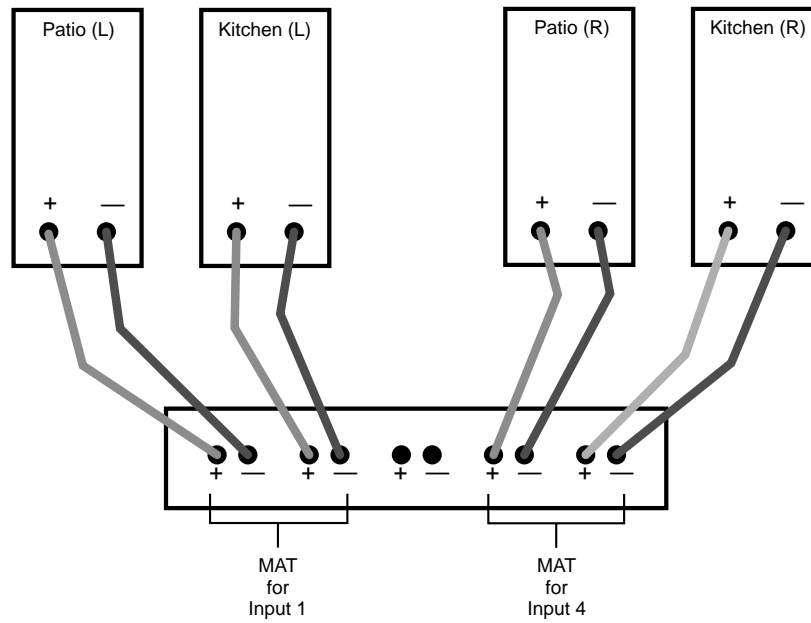

Questions and Answers

Q. Should I turn the Theater Amplifier Standard off when not playing music?

A. No. Leave the Theater Amplifier Standard in the stand-by mode when not playing music. The stand-by mode avoids cold starts as well as minimizes heat output and power consumption. Krell recommends turning the amplifier off if you plan to be away for a period of time, for example, on vacation. See ***Amplifier Operation***, on page 13.

Q. When I turn the amplifier on there is a loud hum through the loudspeakers. What should I do?

A. When a new component is introduced, a low frequency hum may occur in one or both loudspeakers. Check that all input and output connections and cables are of sound construction. See ***Troubleshooting System Noise***, on page 14. If the connections and cables are sound, you may be experiencing a ground loop. This can often be easily eliminated. Please contact your authorized Krell dealer, distributor, or Krell for suggestions.

Q. When I connect the amplifier to my system using the single-ended inputs, a loud buzz comes from my loudspeakers. What is it?

A. Check that the shorting pins for the Theater Amplifier Standard are inserted into the XLR inputs (the unit is shipped with the pins in place). When using the single-ended inputs, the shorting pins must be inserted between pins 1 and 3 to keep external noise from corrupting the signal. For more information, see ***Connecting the Theater Amplifier Standard to Your System***, on page 11.

Q. Can I bridge all the channels on my Theater Amplifier Standard?

A. No. You can bridge four of the amplifier's five channels: 1, 2, 4, and 5. Channel 3 cannot be bridged.

Q. Will I be able to use the amplifier without reconfiguring the channels for MAT or bridged operation?

A. Yes. The Theater Amplifier Standard is shipped from the factory ready to play music. The default settings allow you to connect each amplifier channel output to a separate loudspeaker. See ***Figure 3***, on page 16. MAT and bridging reconfigurations are optional.

Warranty

To register your product for warranty benefits, please complete and return the Warranty Registration Card enclosed in the shipping box within 15 days of purchase. Thank you.

This Krell product has a limited warranty of five years for parts and labor on circuitry. Should this product fail to perform at any time during the warranty, Krell will repair it at no cost to the owner, except as set forth in this warranty.

The warranty does not apply to damage caused by acts of God or nature.

The warranty on this page shall be in lieu of any other warranty, expressed or implied, including, but not limited to, any implied warranty of merchantability or fitness for a particular purpose. There are no warranties which exceed beyond those described in this document. If this product does not perform as warranted herein, the owner's sole remedy shall be repair. In no event will Krell be liable for incidental or consequential damages arising from purchase, use, or inability to use this product, even if Krell has been advised of the possibility of such damages.

Proof of purchase in the form of a bill of sale or receipted invoice substantiating that the unit is within the warranty period must be presented to obtain warranty service. The warranty begins on the date of the original retail purchase, as noted on the bill of sale or receipted invoice from an authorized Krell dealer or distributor. Previously owned equipment, when re-purchased from an authorized Krell dealer or distributor, has the balance of the original warranty, based on the original date of manufacture.

The warranty for Krell products is valid only in the country to which they were originally shipped, through the authorized Krell distributor for that country, and at the factory. There may be restrictions on or changes to Krell's warranty because of regulations within a specific country. Please check with your distributor for a complete understanding of the warranty in your country.

If a unit is serviced by a distributor who did not import the unit, there may be a charge for service, even if the product is within the warranty period.

Freight to the factory is your responsibility. Return freight within the United States (U.S.A.) is included in the warranty. If you have purchased your Krell product outside the U.S.A. and wish to have it serviced at the factory, all freight and associated charges to the factory are your responsibility.

Krell will pay return freight to the U.S.A.-based freight forwarder of your choice. Freight and other charges to ship the unit from the freight forwarder to you are also your responsibility.

Krell is not responsible for any damage incurred in transit. Krell will file claims for damages as necessary for units damaged in transit to the factory. You are responsible for filing claims for shipping damages during the return shipment.

Krell does not supply replacement parts and/or products to the owner of the unit. Replacement parts and/or products will be furnished only to the distributor performing service on this unit on an exchange basis only; any parts and/or products returned to Krell for exchange become the property of Krell.

No expressed or implied warranty is made for any Krell product damaged by accident, abuse, misuse, natural or personal disaster, or unauthorized modification.

Any unauthorized voltage conversion, disassembly, component replacement, perforation of chassis, updates, or modifications performed to the unit will void the warranty.

The operating voltage of this unit is determined by the factory and can only be changed by an authorized Krell distributor or at the factory. The voltage for this product in the U.S.A. cannot be changed until six months from the original purchase date.

In the event that Krell receives a product for warranty service that has been modified in any way without Krell authorization, all warranties on that product will be void. The product will be returned to original factory layout specifications at the owner's expense before it is repaired. All repairs required after the product has been returned to original factory specifications will be charged to the customer, at current parts and labor rates.

All operational features, functions, and specifications and policies are subject to change without notification.

Return Authorization Procedure

HOW TO EXPEDITE SERVICE

If you believe there is a problem with your component, please contact your dealer, distributor, or the Krell factory to discuss the problem *before* you return the component for repair. To expedite service, you may wish to complete and e-mail the Service Request Form in the Service section of our website at:

<http://www.krellonline.com>

To contact the Krell Service Department:

TEL	203-799-9954 Monday-Friday, 9:00 am to 5:00 pm EST
FAX	203-799-9796
E-MAIL	service@krellonline.com
WEBSITE	http://www.krellonline.com

HOW TO RETURN A PRODUCT

To return a product to Krell, please follow this procedure so that we may serve you better:

1. Obtain a Return Authorization Number (R/A number) and shipping address from the Krell Service Department.
2. Insure and accept all liability for loss or damage to the product during shipment to the Krell factory and ensure all freight (shipping) charges are prepaid.

The product may also be hand delivered if arrangements with the Service Department have been made in advance. Proof of purchase will be required for warranty validation at the time of hand delivery.

IMPORTANT

Use the original packaging to ensure the safe transit of the product to the factory, dealer, or distributor. Krell may, at its discretion, return a product in new packaging and bill the owner for such packaging if the product received by Krell was boxed in nonstandard packaging or if the original packaging was so damaged that it was unusable. If Krell determines that new packaging is required, the owner will be notified before the product is returned.

HOW TO PURCHASE ADDITIONAL PACKING

To purchase additional packaging, please contact your authorized Krell dealer, distributor, or the Krell Service Department for assistance.

SERIAL NUMBER

Your Theater Amplifier Standard product serial number is:

Specifications

Theater Amplifier Standard

FREQUENCY RESPONSE	20 Hz to 20 kHz 0.25 Hz to 170 kHz	+0 dB, -0.09 dB +0 dB, -3 dB
SIGNAL TO NOISE RATIO "A" WEIGHTED	>110 dB	
TOTAL HARMONIC DISTORTION (THD)	1 kHz < 0.03% 20 kHz < 0.20%	
GAIN	25.8 dB	
INPUT IMPEDANCE	100 kOhms	
INPUT SENSITIVITY	2.05 Vrms	
OUTPUT VOLTAGE	Peak to Peak RMS	113 V 40 V
OUTPUT POWER EACH CHANNEL	8 Ohms 4 Ohms	200 W 400 W
BRIDGED	8 Ohms	800 W
POWER CONSUMPTION	Standby Idle Max.	60 W 170 W 2500 W
INPUTS	5 single-ended via RCA connectors 5 balanced via XLR connectors 5 via DB-25 connector	
OUTPUTS	5 amplifier channels via five-way binding posts	
REMOTE CONNECTORS	12 VDC Out (12 V trigger) via a 3.5 mm connector 12 VDC In (12 V trigger) via a 3.5 mm connector	
DIMENSIONS	17.3w x 9.8h x 17.0d in. 43.8w x 24.8h x 43.2d cm	
WEIGHT		
SHIPPING	110 lb., 50 kg	
UNIT ONLY	100 lb., 45.5 kg	

All operational features, functions, specifications, and policies are subject to change without notification.

Krell Industries, Inc.
45 Connair Road
Orange, CT 06477-3650 USA

TEL 203-799-9954
FAX 203-891-2028
E-MAIL krell@krellonline.com
WEBSITE <http://www.krellonline.com>

Theater Amplifier Standard

Multichannel Amplifier

v 02.0